**IF190X – IF180X IMPACT PRINTER CONTROLLER
SERIES
Operation Manual - Version 2.1
June 2002**

Revision list for the PANEL10 impact printers operation manual.

Date: 28 - 6 - 2002

Page	Type of revision	Before change	After change
15-16	add		Information about the current peaks consumption.

INDEX

IMPORTANT NOTES ON PANEL-10 HANDLING	4
1- INTRODUCTION	5
2- INSTALLATION	7
2.1 Installing PANEL – 10 printer series	7
2.1.1 Connectors location	8
2.2 Installing the 190X / 180X interfaces	9
2.2.1 Connecting EPSON M-190/M-192 micro dot printer mechanism to IF190X interface	9
2.2.2 Connecting EPSON M-190G/M-192G micro dot printer mechanism to IF190X interface	11
2.2.3 Connecting EPSON M-180/M-183 micro dot printer mechanism to IF180X interface	13
2.2.4 Connecting the external components	15
2.3 Power supply connector	15
2.4 Serial port connector (RS-232/TTL)	17
2.4.1 Serial port configuration	17
2.5 Parallel port connector (CENTRONICS)	19
2.6 Interfacing with a personal computer	20
2.6.1 Parallel input/output	20
2.6.2 Serial input/output	21
3- BASIC OPERATIONS	22
3.1 Loading paper	22
3.2 Ribbon Cassette handling	23
3.3 Paper feed	23
3.4 Self – Test feature	24
3.5 Hexadecimal mode	25
3.6 Sending data to the printer	26
3.6.1 Serial transmission	26
3.6.2 Parallel transmission	28
4-PRINTER COMMANDS	30
4.1- Control commands	31
4.2- Text printing	35
4.3- Graphics printing	37
4.4- Graphics layout	38
4.5- Printer command summary	41
APPENDIX A – PANEL10 PHYSICAL DIMENSIONS	42
APPENDIX B - TROUBLESHOOTING	45
APPENDIX C - SOFTWARE EXAMPLES	46
APPENDIX D - SPECIFICATIONS	46
APPENDIX E - HOW TO ORDER	47

IMPORTANT NOTES ON PANEL-10 HANDLING

In order to guarantee a long life of the printer, it is necessary to keep some precautions on PANEL-10 handling. Please read carefully next lines to make a good use of the printer.

- Beware not to invert power supply polarity. This may irremediably damage the printer. FENIX recommends the use of 4 wires (minimum section = 2 mm²) for the corresponding 4 power supply connector contacts.
- Use power supply voltage within specified range. Overvoltage may irremediably damage the printer. Voltage under the specified range may cause incorrect operations.
- Before connecting any input interface, verify the correct operation of PANEL-10 printer with self test feature.
- Avoid using PANEL-10 printer in environments where there are excessive temperatures or moisture.
- Printing without paper or ribbon is prohibited to avoid damaging the printer.
- Conditions on inside end of roll paper (with or without a core):
 - No fold is allowed. The paper must be wound so that the paper edge goes along the internal circumference.
 - No folding back is allowed.
 - No folds, wrinkles or tears are allowed.
 - Inside end must not be glued to the core (when a core exist).
 - Neither perforations nor holes can be positioned within the printable area.
 - When printing is stopped in the middle of a print job and the paper is reset after being pulled out or moved, printing position and pitch cannot be guaranteed for subsequent printing.

1.- INTRODUCTION

PANEL-10 is a low cost - high performance impact printer series which covers any application in hard environment as intense vibrations or shocks, corrosive places, etc.

FENIX supplies PANEL – 10 impact– 10 impact printers printer series as a terminated product where the EPSON printer mechanism (M180, M183, M190, M192, M190G, M192G) and its suitable interface (IF190X, IF180X) have been incorporated to a plastic chassis with the purpose of panelling the system.

FENIX INTERFACES	EPSON MECHANISMS
IF190X	M190, M192, M190G, M192G
IF180X	M180, M183

The chassis provides PANEL – 10 impact printers with a receptacle to allocate the paper roll, a cover which can be pulled out in order to replace the paper roll, a paper feed button and a power on LED indicator.

PANEL – 10 impact printer series is specially designed to be fixed to panel mechanisms.

Main features of PANEL-10 printers are:

- Easy maintenance structure.
- Easy installation procedure.
- Compact and lightweight.
- Both parallel CENTRONICS and serial RS-232 data input interfaces.
- Real time clock/calendar with storage battery.
- Single +5V power supply.
- Allowed mixing attributes in the same line: normal, double height, underline and double width .
- Automatic interline paper feed.
- Hexadecimal mode for easy software debugging.
- Graphic bitmap printing capabilities.
- Programmable character and line spacing.
- Self test feature.

This manual is a guide of printer operations and is addressed to the application's designer. In following chapters there is a detailed description of hardware and software configuration to use the features of PANEL-10 impact printer.

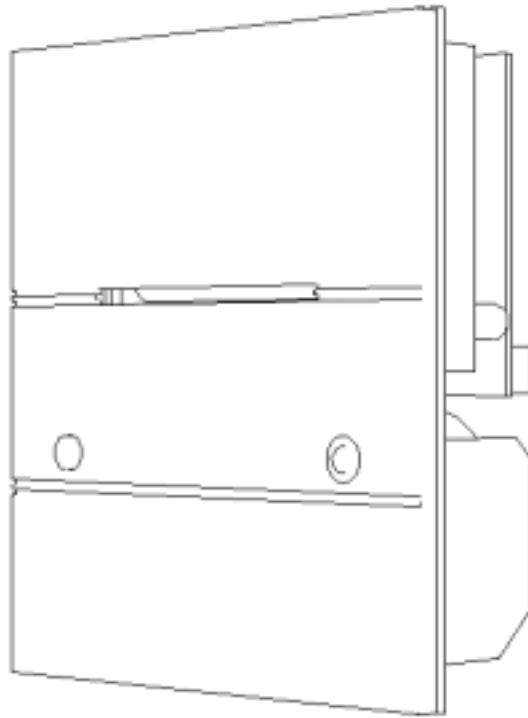

Fig. 1.1- PANEL-10 Impact printer.

The PANEL – 10 impact printer series can be ordered as a terminated product or simply as the desired EPSON mechanism and its corresponding FENIX interface. For more information see **APPENDIX E - HOW TO ORDER.**

2.- INSTALLATION

2.1.- INSTALLING PANEL – 10 PRINTER SERIES

To install PANEL – 10 printers follow these steps:

- Make a rectangular hole of 116 x 96.5 mm on the surface where the printer will be set.
- Pull out the frontal cover and place the printer in the hole.
- Screw down the printer with metric screws DIN965-M3x6 (Part **A** in **Fig. 2.1**) by the holes marked with a **B**.
- Put the cover back in its place.
- Connect the power supply and the communications port from the back side of the printer as shown in next points.

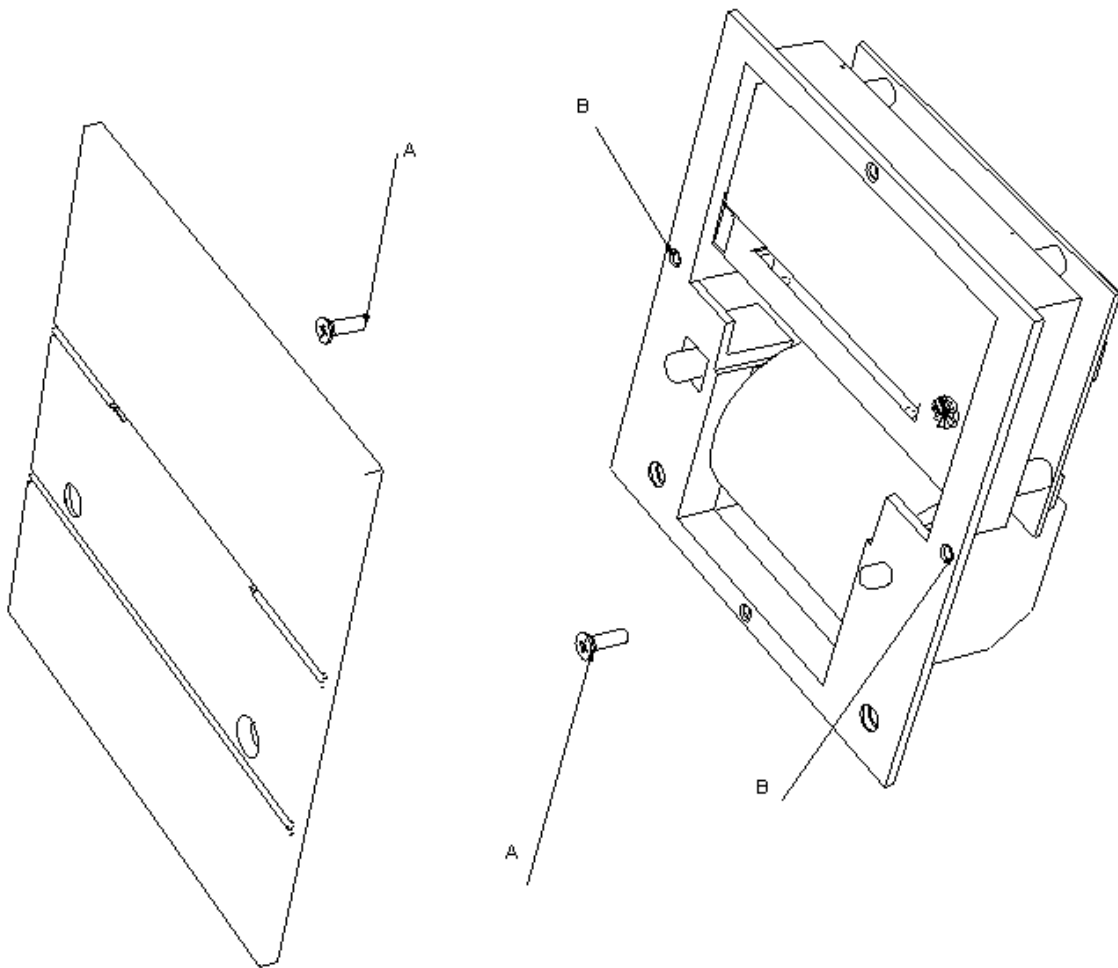

Fig. 2.1.- PANEL-10 installation.

2.1.1.- CONNECTORS LOCATION

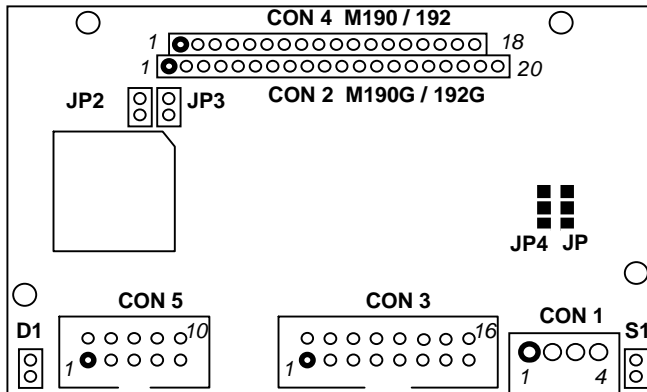

Fig. 2.2 – IF190X impact printer controller connectors for EPSON M190 / M192 or M190G / M192G mechanisms.

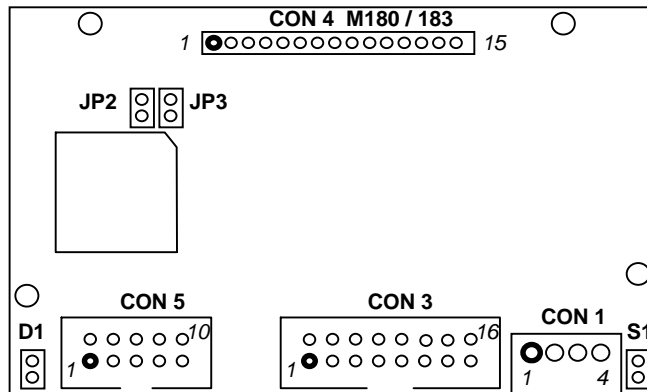

Fig. 2.3 – IF180X impact printer controller connectors for EPSON M180 / M183 interfaces.

2.2.- INSTALLING THE IF190X / IF180X INTERFACES

If not using the terminated product PANEL – 10 printer, user must previously make the connections specified from points **2.2.1** to **2.2.4**

2.2.1.- CONNECTING EPSON M-190 / M-192 MICRO DOT PRINTER MECHANISM TO IF190X INTERFACE

If using M-190 / M-192 micro dot printer connect it to **CON 4** (see **fig. 2.4**).

Terminal nº	Signal Name	Function
1	FASTPF1	Fast Paper Feed Trigger Solenoid
2	FASTPF2	Fast Paper Feed Trigger Solenoid
3	RESET1	Reset Detector
4	RESET2	Reset Detector
5	MOTOR(+)	Motor (+)
6	MOTOR(-)	Motor (-)
7	SOLB	Print Solenoid (B)
8	SOLC	Print Solenoid (C)
9	SOLD	Print Solenoid (D)
10	SOLE	Print Solenoid (E)
11	SOLF	Print Solenoid (F)
12	SOLG	Print Solenoid (G)
13	SOLH	Print Solenoid (H)
14	SOLCOM1	Common for Print Solenoids
15	SOLCOM2	Common for Print Solenoids
16	SOLA	Print Solenoid (A)
17	TIMING1	Timing Detector
18	TIMING2	Timing Detector

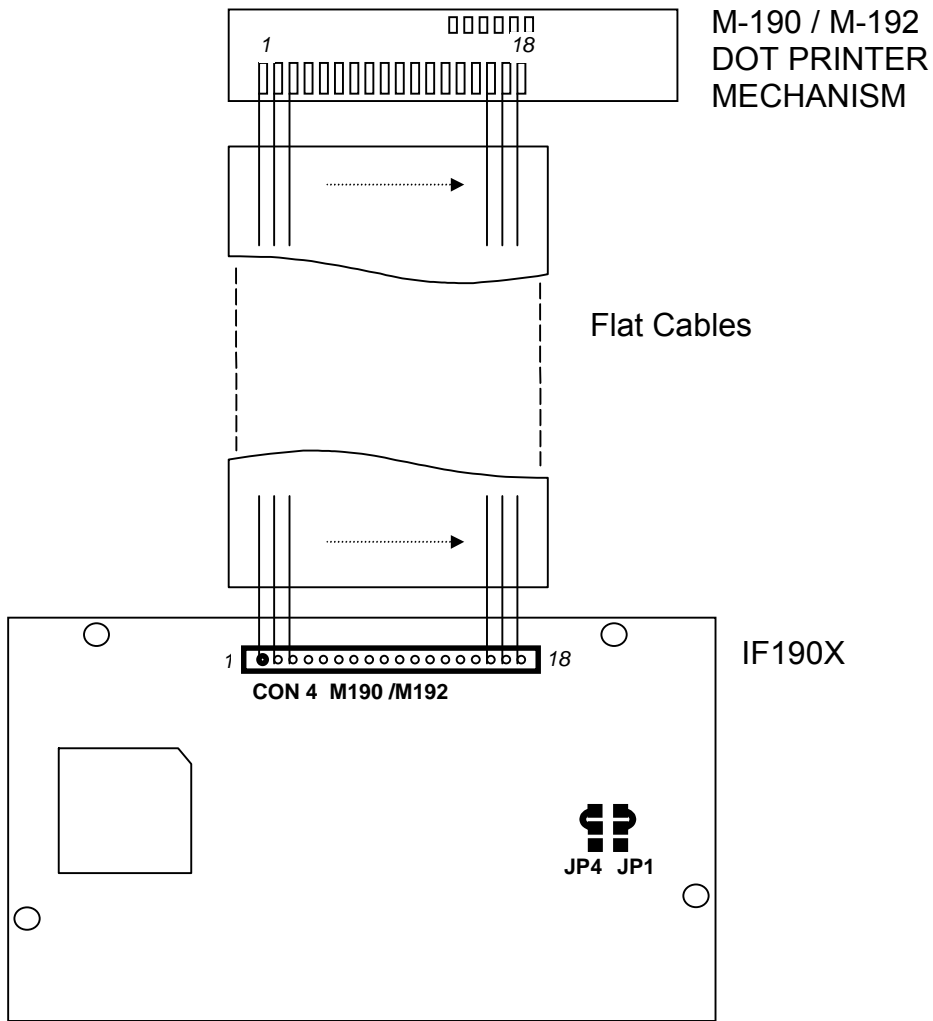

Fig. 2.4.- Connecting EPSON M-190 / M-192 Printer to IF190X **CON 4** printer terminals.

To check the correct connection of the mechanism please follow next steps:

- 1.- Solder **JP1** and **JP4** pads as shown in fig. **2.4**.
- 2.- Connect **CON 4** printer terminals to M-190 /M-192 mechanism.
Note that the left most terminal is num. 1 and the right most terminal is num. 18, both in the printer and in the interface boards, as shown in **fig. 2.4**.

NOTE: To guarantee a better connection, the use of flat cables strip is recommended (using 1mm² minimum section and 50 mm maximum length wires).

2.2.2 CONNECTING EPSON M-190G / M-192G MICRO DOT PRINTER MECHANISM TO IF190X INTERFACE

If using M-190G / M-192G micro dot printer connect it to **CON 2** (see **fig. 2.5**).

Terminal nº	Signal Name	Function
1	FASTPF1	Fast Paper Feed Trigger Solenoid
2	FASTPF2	Fast Paper Feed Trigger Solenoid
3	RESGND	Reset Detector. GND
4	RESW	Reset Detector. Waveform
5	RESVCC	Reset Detector. +5V
6	MOTOR(+)	Motor (+)
7	MOTOR(-)	Motor (-)
8	SOLB	Print Solenoid (B)
9	SOLC	Print Solenoid (C)
10	SOLD	Print Solenoid (D)
11	SOLE	Print Solenoid (E)
12	SOLF	Print Solenoid (F)
13	SOLG	Print Solenoid (G)
14	SOLH	Print Solenoid (H)
15	SOLCOM1	Common for Print Solenoids
16	SOLCOM2	Common for Print Solenoids
17	SOLA	Print Solenoid (A)
18	TW	Timing Detector. Waveform
19	TGND	Timing Detector. GND
20	TVCC	Timing Detector. +5V

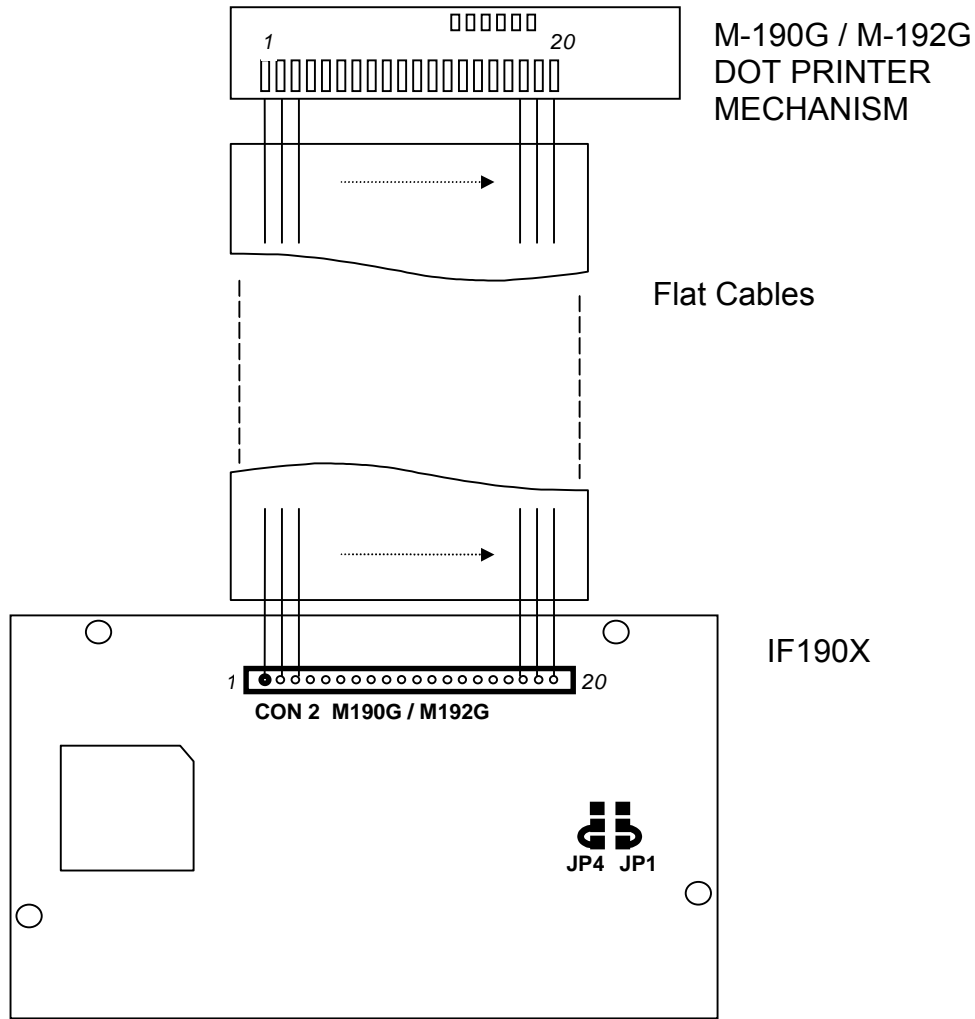

Fig. 2.5.- Connecting EPSON M-190G / M-192G Printer to IF190X **CON 2** printer terminals.

In order to check the correct connection of the mechanism please follow next steps:

- 1.- Solder **JP1** and **JP4** pads as shown in **fig. 2.5**.
- 2.- Connect **CON 2** printer terminals to M-190G / M-192G printer mechanism.

Note that the most left terminal is num. 1 and the right most terminal is num. 20, both in the printer and in the interface boards.

NOTE: To guarantee a better connection, the use of flat cables strip is recommended. (using 1mm² minimum section and 50 mm maximum length wires).

2.2.3.- CONNECTING EPSON M-180 / M-183 MICRO DOT PRINTER MECHANISM TO IF180X INTERFACE

If using M-180 / M-183 micro dot printer connect it to **CON 4** (see **fig. 2.6**).

Terminal nº	Signal Name	Function
1	FASTPF1	Fast Paper Feed Trigger Solenoid
2	FASTPF2	Fast Paper Feed Trigger Solenoid
3	RESET1	Reset Detector
4	RESET2	Reset Detector
5	MOTOR(+)	Motor (+)
6	MOTOR(-)	Motor (-)
7	SOLB	Print Solenoid (B)
8	SOLC	Print Solenoid (C)
9	SOLD	Print Solenoid (D)
10	SOLE	Print Solenoid (E)
11	SOLF	Print Solenoid (F)
12	SOLCOM1	Common for Print Solenoids
13	SOLA	Print Solenoid (A)
14	TIMING1	Timing Detector
15	TIMING2	Timing Detector

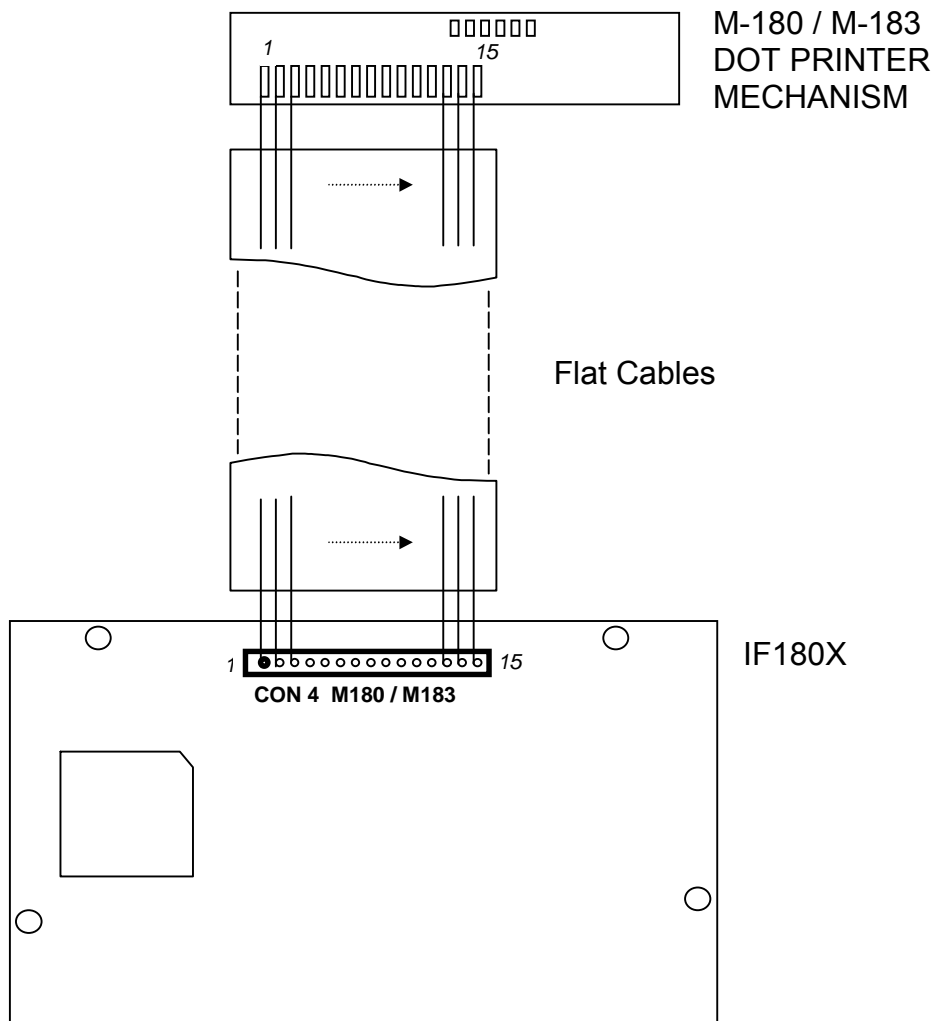

Fig. 2.6.- M-180 / M-183 Micro Dot Printer Connector CON 4.

In order to check the correct connection of the mechanism please follow next steps:

- 1.- Connect **CON 4** printer terminals to M-180 / M-183 mechanism.
Note that the left most terminal is num. 1 and the right most terminal is num. 15, both in the printer and in the interface boards.

NOTE: To guarantee a better connection, the use of flat cables strip is recommended. (using 1mm² minimum section and 50 mm maximum length wires).

2.2.4.- CONNECTING THE EXTERNAL COMPONENTS

If the IF190X/IF180X interface is used without the PN10 printer chassis, connect the external components as shown in **fig. 2.7**.

The power - on LED and the paper feed push - button must be soldered on the board pads.

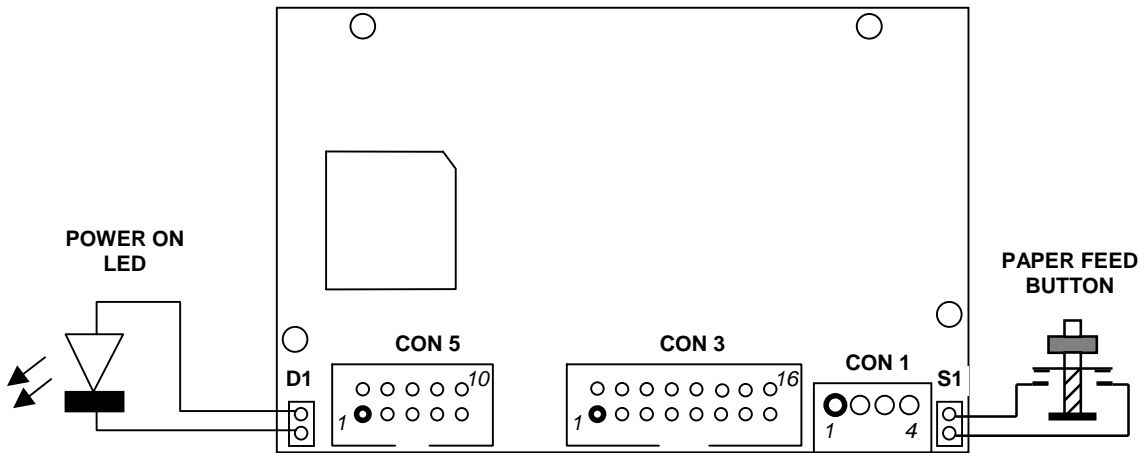

Fig. 2.7- External components for IF190X/IF180X.

2.3.- POWER SUPPLY CONNECTOR

Attach power supply cable to connector **CON 1** (see **fig.2.8**). Verify power supply voltage before making the connection.

Terminal n°	Signal Name	Function
1	GND	GND
2	VCC	Printer power (5v dc)
3	VCC	Printer power (5v dc)
4	GND	GND

Fig. 2.8. Power supply connector (**CON 1**).

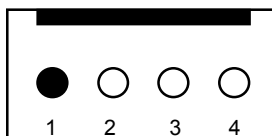

Use a connector Ref. JST
(or compatible)

VHR-4N (housing)
SVH-21T-P1.1 (contacts)

WARNING : Beware not to invert the polarity of power supply. This may irretrievably damage the printer. FENIX recommends the use of 4 wires (minimum section = 2 mm²) for the corresponding 4 power supply connector contacts.

Beware to respect consumption limits according to next table:

	M-190 / M-192 M-190G / M-192G	M-180 / M-183
Maximum Power Consumption	7.5 A peak MAX.	6 A peak MAX.

The necessary power supply depends on content printed in the ticket. The manufacturer of the impact mechanism, Epson, shows for M-190/M-192 a peak current of max. 2.5 A/solenoid, although the experience teaches us that standard peak current to be considered is around a 60% of this value. This means we are talking a peak current of approx. 4.5 A to 5 A (2.5 A x 3 solenoids * x 60%).

*number of needles activated simultaneously.

The recommended power supply for our PN10-190X or PN10-192X should be approximately of nominal 2,5 A or more, but able to support peak currents of 4.5 A. Anyway, the customer should test the power supply to use, adjusting it in accordance to his printing needs, since if in the exceptional cases he may need peak currents of 6.5 A or even 7.5 A, printer would reset itself.

For a total security, if customer uses a power supply able to support peak current of 7.5 A, printer would remain fully covered.

The necessary power supply depends on content printed in the ticket. The manufacturer of the impact mechanism, Epson, shows for M-180/M-183 a peak current of max. 3 A/solenoid, although the experience teaches us that standard peak current to be considered is around a 60% of this value. This means we are talking a peak current of approx. 3.6 A to 4 A (3 A x 2 solenoids * x 60%).

*number of needles activated simultaneously.

The recommended power supply for our PN10-180X or PN10-183X should be approximately of nominal 2,5 A or more, but able to support peak currents of 4 A. Anyway, the customer should test the power supply to use, adjusting it in accordance to his printing needs, since if in the exceptional cases he may need peak currents of 5 A or even 6 A, printer would reset itself.

For a total security, if customer uses a power supply able to support peak current of 6 A, printer would remain fully covered.

2.4.- SERIAL PORT CONNECTOR (RS-232/TTL)

If you use serial interface, attach serial port cable to connector **CON 5** (see **fig.2.9**).

Terminal nº	Signal Name	Function
1	DTR	Out→Data Terminal Ready
2	DSR	In ←Data Source Ready
3	TxD	Out→Transmit Data
4	CTS	In ←Clear To Send
5	RxD	In ←Receive data
6	RTS	Out→Request To Send
7-8	NC	-
9-10	GND	GND

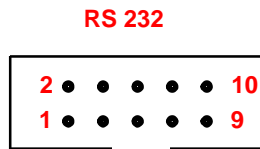

Fig. 2.9 - RS-232/TTL connector CON 5.

Use a connector JST Ref.- RA-1011 (housing)
(or ompatible) RA-SC1290 (contacts)

2.4.1.- SERIAL PORT CONFIGURATION

Configuration of the IF190X/IF180X interface has been reduced to a minimum.

If serial port is used, baud rate must be configured by on – board jumpers (**JP2, JP3**, see **fig. 2.10**).

It is not necessary to select any data input interface. IF190X/IF180X interface receives data by any data inputs (parallel or serial) without any configuration.

Serial port configuration is reduced to baud rate configuration. Baud rate configuration is loaded after printer is reset.

- **Parity is fixed to NONE.**
- **Stop bit is fixed to 1 STOP BIT.**
- **Bits/character is fixed to 8 bits.**

Baud rate is configured by two on – board jumpers (**JP2**, **JP3**) as shown below.

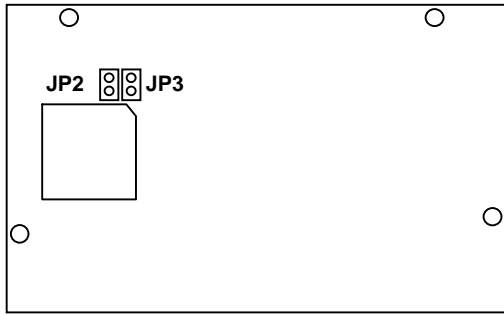

JP 3	JP2	BAUD RATE
0	0	19200
0	1	9600
1	0	4800
1	1	2400

Fig. 2.10- Baud rate jumpers on IF190X /IF180X interface.

“0” = SHORTED

“1” = NOT SHORTED

2.5.- PARALLEL PORT CONNECTOR (CENTRONICS)

If you use parallel interface, attach CENTRONICS cable to connector **CON 3** (see **fig. 2.11**).

Terminal nº	Signal Name	Function
1	/STB	In ← Strobe
2	DATA0	In ← Data Bus
3	DATA1	
4	DATA2	
5	DATA3	
6	DATA4	
7	DATA5	
8	DATA6	
9	DATA7	
10	/ACK	Out→Acknowledge
11	BUSY	Out→Busy
12	PE	Out→Paper Error
13	/ERROR	Out→Error
14-16	GND	GND

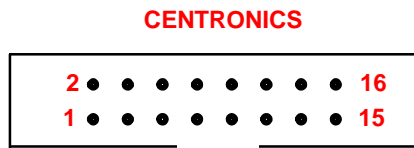
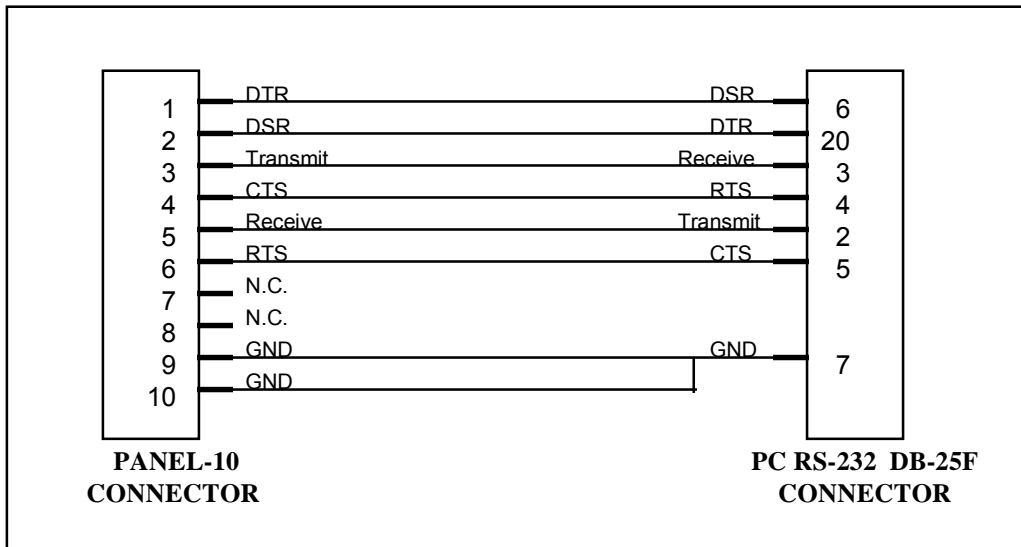
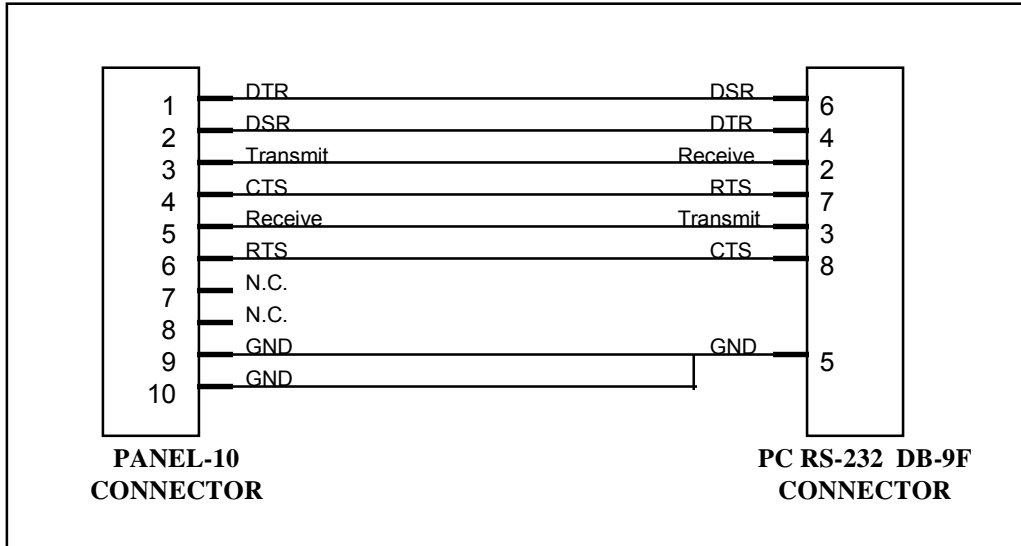

Fig. 2.11 - Centronics connector CON 3.

Use a connector JST Ref.- **RA-1611 (housing)**
 (or compatible) **RA-SC1290 (contacts)**

2.6.2.- SERIAL INPUT / OUTPUT

Following drawings show how to make the interface cables with a compatible PC RS232 connector (DB-9 or DB-25).



RS 232

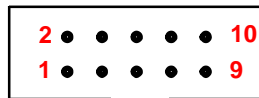

Fig. 2.13 - RS-232 cable pinout

Use a connector JST Ref.-
(or compatible)

RA-1011 (housing)
RA-SC1290 (contacts)

3.- BASIC OPERATIONS

3.1.- LOADING PAPER

Follow next steps to load the paper roll:

- 1.- Pull out the frontal cover and place the paper roll in its receptacle in the position shown in **fig. 3.1**.
- 2.- Insert the end of the paper roll in the slit of the printer marked as **PAPER LOAD** in **fig. 3.1**.
- 3.- Press the FEED button until a few centimeters come out of the printer.
- 4.- Make sure that the paper roll remains in its receptacle in the right position shown in **fig. 3.1**, and put the frontal cover back in its place.

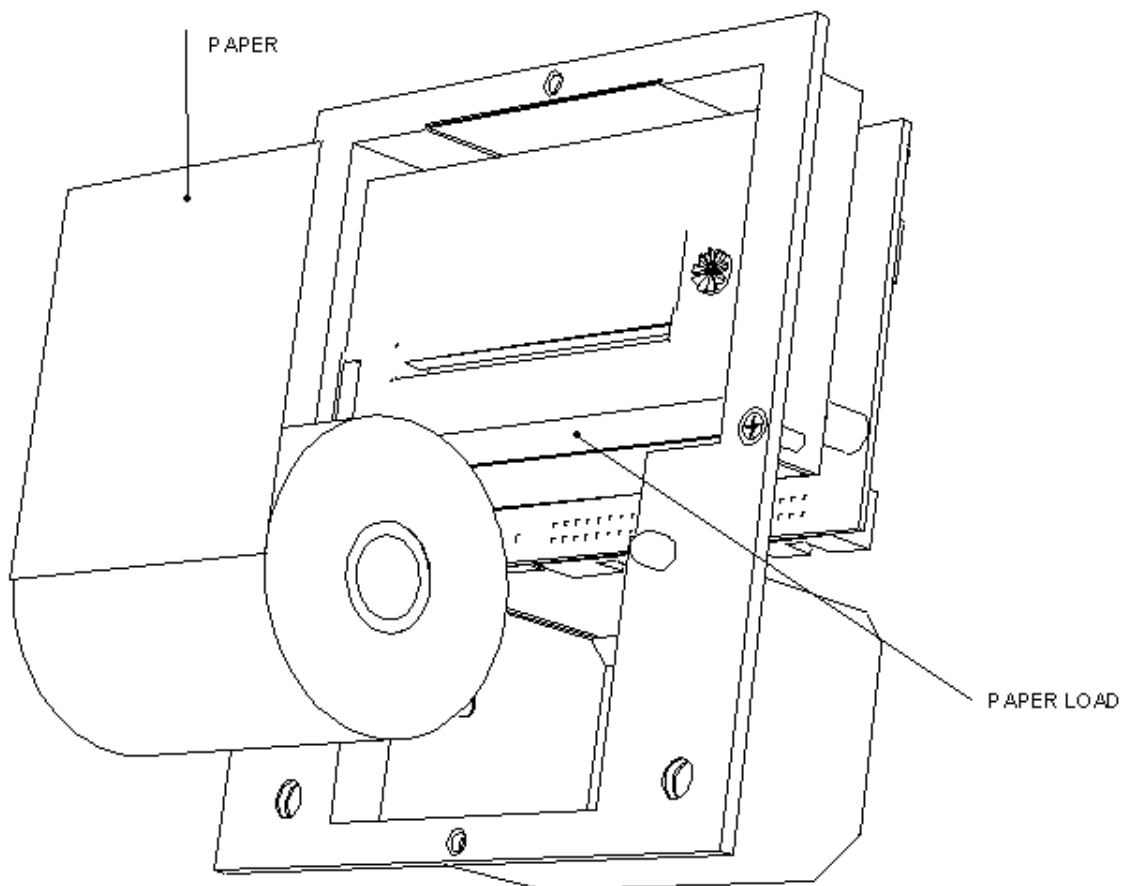

Fig. 3.1 - Cut paper to load

3.2.- RIBBON CASSETTE HANDLING

- 1.- Before mounting the ribbon cassette, it is desirable to remove the paper.
- 2.- The ribbon cassette can be easily installed by pushing it down softly. If ribbon is tucked up or if it sags while mounting, it can be tightened and fixed to its proper position by rotating the roller after inserting the cassette frame.
- 3.- To remove the ribbon cassette, push the portion marked **PUSH** with a finger. The other side of the cassette will go up (See **fig. 3.2**).

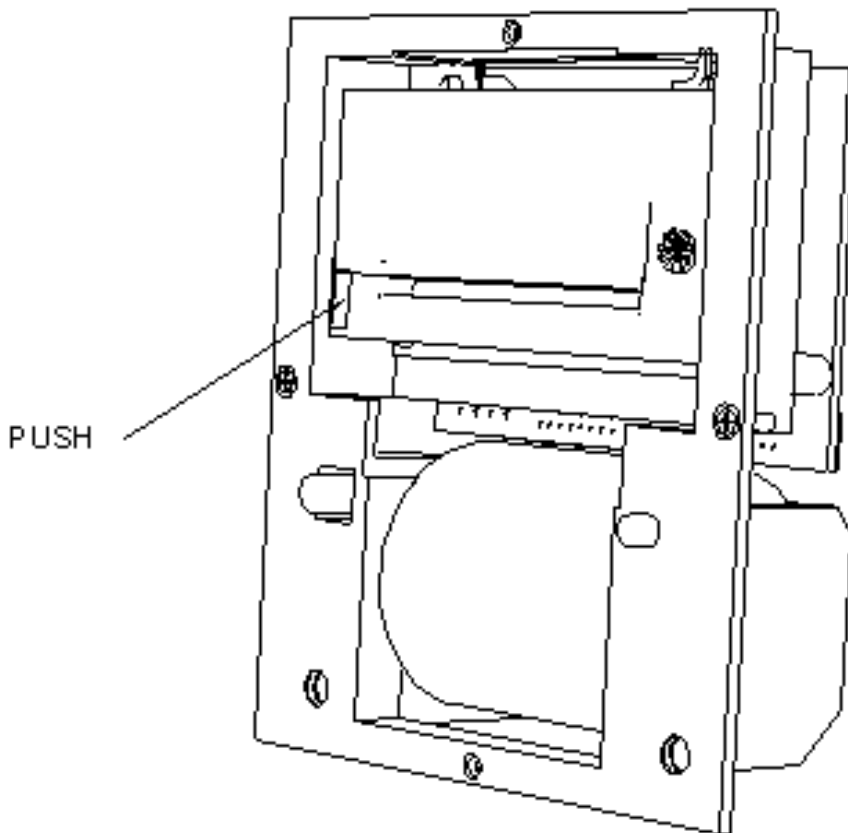

Fig. 3.2 Removing the ribbon cassette.

3.3.- PAPER FEED

Both IF190X and IF180X interfaces have two on-board pads (see **2.2.4.- CONNECTING THE EXTERNAL COMPONENTS**) to solder the push - button cables. Its main function is to allow user to do paper feeding when paper is loaded. Paper is fed until the push – button is released.

3.4.- SELF – TEST FEATURE

Before connecting any data interface, check the correct operation of printer using self-test feature.

To enter self – test mode, user must power the printer on with paper feed button pressed. Self – test mode prints a rapport about the PANEL – 10 configuration. It also prints the character set in normal format.

PANEL – 10 character set: (coordenates expressed in hexadecimal code)

HI LO	0	1	2	3	4	5	6	7	8	9	A	B	C	D	E	F
0				0	@	P	`	p	Ç	É	á	☒	⌒	⌒	α	≡
1			!	1	A	Q	a	q	ü	æ	í	☒	⌒	⌒	β	±
2			“	2	B	R	b	r	é	Æ	ó	☒	⌒	⌒	Γ	≥
3			#	3	C	S	c	s	â	ô	ú		⌒	⌒	π	≤
4			\$	4	D	T	d	t	ä	ö	ñ	⌒	—	⌒	Σ	∫
5			%	5	E	U	e	u	à	ò	Ñ	⌒	⌒	⌒	σ	∫
6			&	6	F	V	f	v	å	û	ª	⌒	⌒	⌒	μ	÷
7			‘	7	G	W	g	w	ç	ù	º	⌒	⌒	⌒	τ	≈
8			(8	H	X	h	x	ê	ÿ	¿	⌒	⌒	⌒	φ	°
9)	9	I	Y	i	y	ë	Ö	⌒	⌒	⌒	⌒	θ	•
A			*	:	J	Z	j	z	è	Ü	⌒	⌒	⌒	⌒	Ω	·
B		ESC	+	;	K	[k	{	ï	ø	½	⌒	⌒	⌒	δ	√
C			,	<	L	\	l		î	£	¼	⌒	⌒	⌒	∞	ⁿ
D			-	=	M]	m	}	ì	¥	ì	⌒	⌒	⌒	∅	²
E			.	>	N	^	n	~	Ä	Pt	«	⌒	⌒	⌒	ε	■
F			/	?	O	_	o	␣	Å	f	»	⌒	⌒	⌒	∩	

NOTE: Taking the standard character set as a basis, a personalized character set can be ordered to FENIX depending on customers needs (please contact your sales agent)

3.5.- HEXADECIMAL MODE

To enter hexadecimal mode user must enter self – test mode and keep the paper feed button pushed until complete rapport has been printed. If the paper feed button is pressed within the next 5 seconds, next text will be printed:

/// *HEXADECIMAL MODE \ \ *

reporting that the system has entered in hexadecimal mode. Otherwise, if the button is not pressed, the system remains in normal mode, waiting for some command or data.

When the hexadecimal mode is activated, all data received is printed in hexadecimal code (no command is performed). Through this function, user can easily confirm whether or not the data sent from the host device is correctly received or if the host device has sent the correct data.

3.6.- SENDING DATA TO THE PRINTER

If 128 bytes have been stored in the IF190X / IF180X input buffer, the busy status continues until the amount of data stored in the input buffer becomes 127 bytes or less.

3.6.1.- SERIAL TRANSMISSION

The IF190X/IF180X interface continues to receive data during print operation.

The IF190X/IF180X interface serial input/output signals (RXD, /RTS and TXD) are RS232C level.

The IF190X/IF180X interface receives and checks serial data according to the transmission programmed baud rate (see **2.2.1.- SERIAL PORT CONFIGURATION**).

If the input data is not correctly printed, it means that the transmission conditions between the host device and the IF190X/IF180x interface do not match. If this happens, adjust the conditions so they match.

Timing Chart

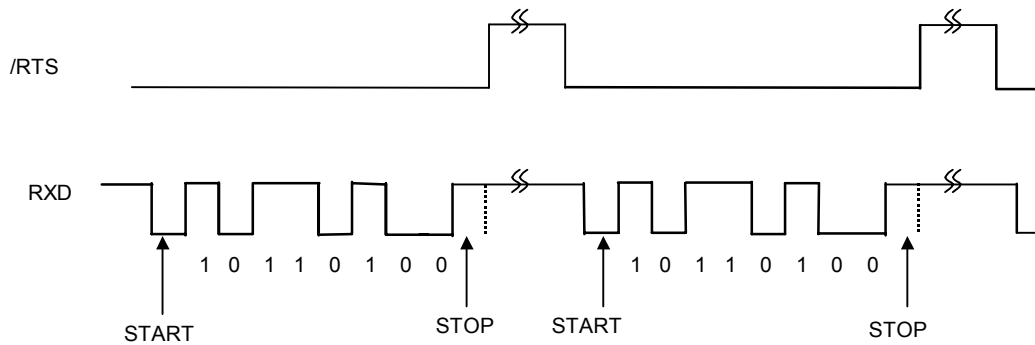

Fig. 3.3 Serial input/output signal timing chart.

Serial data output (TXD): output pin, CON5- 3

- Data is output according to the programmed transmission conditions.

Serial data input (RXD): input pin, CON5- 5

- Data input port
- Data is input from the host device according to the programmed transmission conditions.

Serial busy (/RTS): output pin, CON5- 6

- Indicates whether or not the IF190X/IF180X interface is ready to receive data.
- When the /RTS signal is LOW, data can be input.

Flow chart

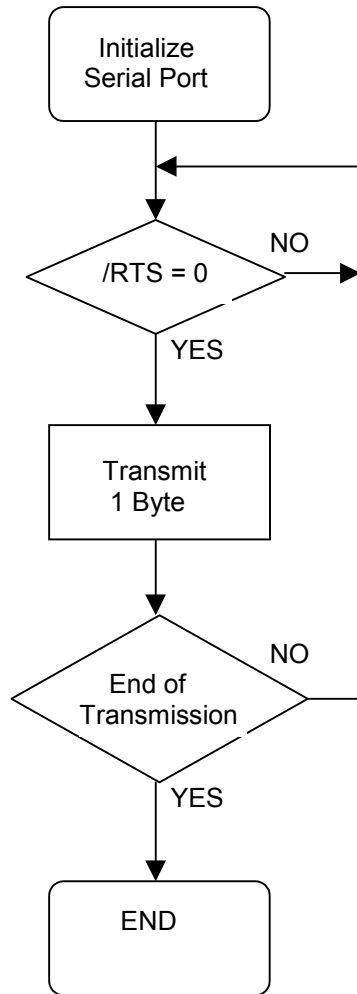

3.6.2.- PARALLEL TRANSMISSION

The busy and acknowledge signals are output every byte.

Timing Chart

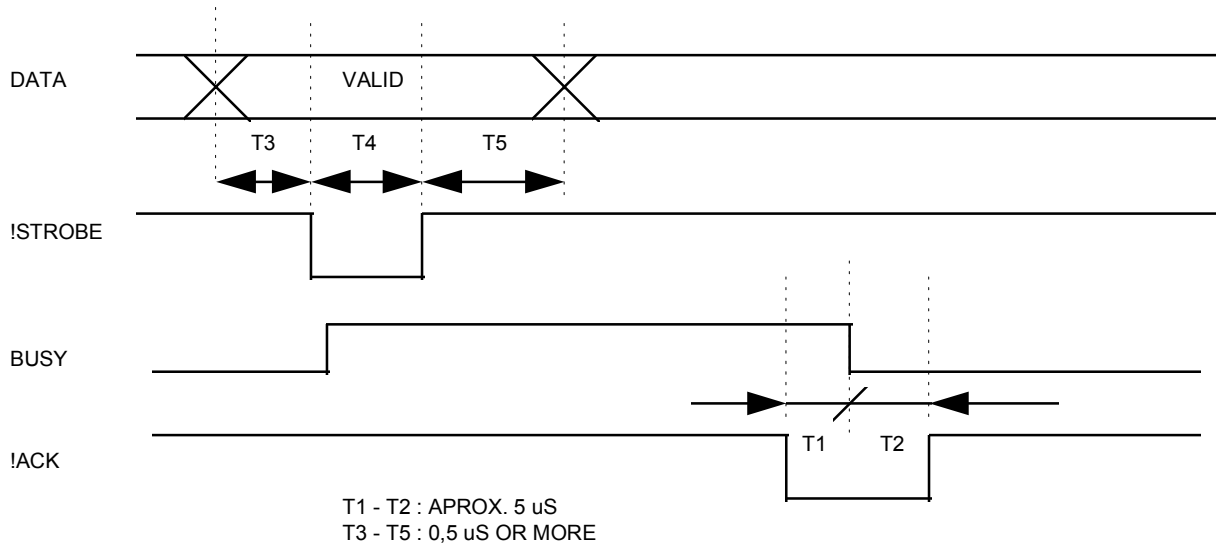

Fig.3.4 - Timing for receiving parallel data.

Strobe (/STROBE) : input pin, CON3-1

- Triggers reading of 8-bit parallel data (DATA0~DATA7).
- This signal is ignored when the BUSY signal is high.
- The /STROBE signal is normally high. The data on the data lines (DATA0~DATA7) are placed into the buffer at the transition of this signal to low.

Data (DATA0~DATA7): input pin, CON3-2 through 9

- Carries 8-bit parallel signals from the host device.
- When high is 1 and low is 0, the data on these lines are placed by the /STROBE signal.

Busy (BUSY): output pin, CON3-11

- The BUSY signal indicates that the IF190X/IF180X interface is ready to receive data.
- When the BUSY signal is low, data can be input. This signal remains high from the transition of the /STROBE signal to low until the time when the data input processing is complete to indicate that the IF190X/IF180X is unable to receive data.

Acknowledge (/ACK): output pin, CON3-10

- The /ACK signal indicates that data reception is complete.

- The /ACK signal is normally high. A pulse approximately 5 uS wide is generated when one-byte of data has been input. The IF190X/IF180X interface generates this signal to indicate to the host device that it can receive further input data.

Flow Chart

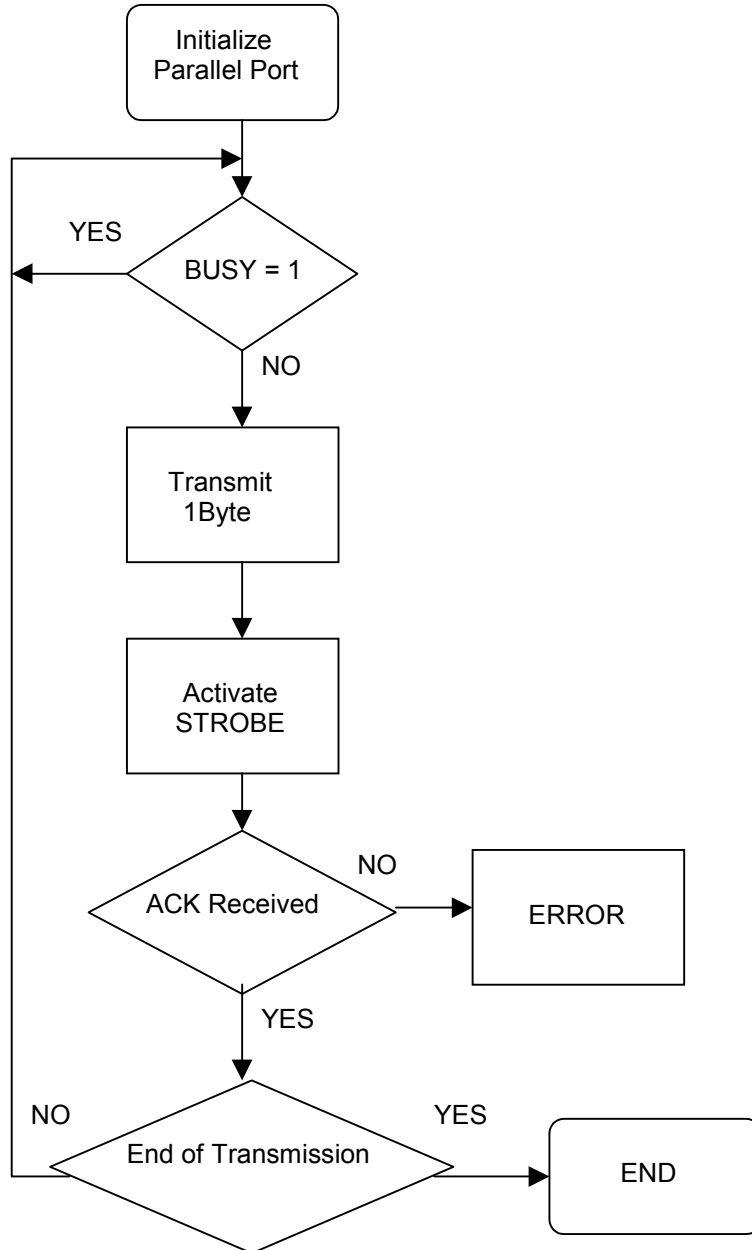

4.- PRINTER COMMANDS

PANEL-10 printer have two printing modes of operation. First is text mode, which prints normal text in ASCII code. Second is graphic mode which allows printing bitmap images and pictures.

PANEL-10 printer is designed like a terminal which can recognize some software control codes. There are some codes which perform the same action. This is for compatibility with some popular printers.

Control codes may be classified into several groups:

CONTROL COMMANDS: This group includes commands which control printer behaviour.

Print action codes:

CAN	CANcel. Delete printer buffer.
CR	Carry Return. Print buffer contents and skip one line.
LF	Line Feed. Print buffer contents and skips one line.
0FH	Set CRLF mode.

Special function control codes:

ESC@	Resets PANEL-10 printer.
ESC J n	Long paper feed n lines (1 line = 3 dots).
ESC j n	Short paper feed n lines (1 line = 1 dot).
n 11H	Paper feed n lines.
ESC H	Print real time/calendar.
12H	Print real time/calendar.
13H	Set real time/calendar.
14H	Send real time/calendar (in serial mode).
ESC T	Set hour in buffer.
ESC D	Set date in buffer.
ESC U	Set date and hour in buffer.
ESC N	Print from left side.
ESC R	Inverse print from right side.
ESC s	Transmits next character in serial.

TEXT PRINTING: Is the group of commands related to text printing.

Text printing commands

00H	Set normal character.
01H	Set double width character.
02H	Set double height character.
04H	Set normal character.
ESC w n	Set double height characters: n="0" off, n="1" on.
ESC W n	Set double width characters: n="0" off, n="1" on.
ESC - n	(ESC minus). Underline: n= "0" off, n="1" on.

GRAPHICS PRINTING: There are two command to print graphics.

ESC V n1 n2 Bit image graphics mode.

11H Bit image graphics mode.

4.1.- CONTROL COMMANDS

CAN	DELETE PRINT BUFFER
------------	----------------------------

Decimal codes: <24>

Hexadecimal codes: <18>

Function:

When received this code, all characters which remain in printing buffer are deleted. This code cancels the last data sent to printer.

CR	CARRY RETURN
-----------	---------------------

Decimal codes: <13>

Hexadecimal codes: <0D>

Function:

This code causes that all data stored in the line buffer are printed. Paper is advanced one character line after executing CR code.

LF	PRINT AND SKIP LINE
-----------	----------------------------

Decimal codes: <10>

Hexadecimal codes: <0A>

Function:

Provides the same function as **CR**. Any **LF** code received immediately following a **CR** is ignored.

ESC @	RESET PRINTER
--------------	----------------------

Decimal codes: <27><64>

Hexadecimal codes: <1B><40>

Function:

This command resets PANEL-10 printer. It's equivalent to hardware reset.

0FH **CRLF MODE**

Decimal codes: <15>

Hexadecimal codes: <0F>

Function:

This control code causes to disable CR command, and enable LF command.

n 0BH **PAPER FEEDING**

Decimal codes: <n><11>

Hexadecimal codes: <n><0B>

Function:

This control code causes to advance paper *n* lines. $0 < n < 9$ (in ASCII).

ESC J n **LONG PAPER FEEDING**

Decimal codes: <27><74><n>

Hexadecimal codes: <1B><4A><n>

Function:

This control code causes to advance paper *n* lines. One line is 3 dots height; *n* parameter is in binary format (not ASCII).

ESC j n **SHORT PAPER FEEDING**

Decimal codes: <27><106><n>

Hexadecimal codes: <1B><6A><n>

Function:

This control code causes to advance paper *n* dot lines. One line is 1 dot height; *n* parameter is in binary format (not ASCII).

13H **SETTING TIME/CALENDAR**

Decimal codes: <19>

Hexadecimal codes: <13>

Function:

This control code allows update time and date. User must input a data string in the following format:

Time/date in decimal : 12:45 19-01-93

String data input: 31H+32H+34H+35H+31H+39H+30H+31H+39H+33H+**13H**

ESC h n d

SETTING TIME/CALENDAR

Decimal codes: <27><104><n><d>

Hexadecimal codes: <1B><68><n><d>

Function:

This control code allows update time and date. Character *n* is time and *d* is the new value. Both *n* and *d* characters are in binary format (not ASCII). User can update time and date by Set190.exe PC program, too.

n = 1	Minutes
n = 2	Hour
n = 4	Date
n = 5	Month
n = 6	Year

Fig. 4.1- *n* character values.

ESC H

PRINTING TIME/CALENDAR

Decimal codes: <27><72>

Hexadecimal codes: <1B><48>

Function:

This control code causes to print actual time/calendar module.

12H

PRINTING TIME/CALENDAR

Decimal codes: <18>

Hexadecimal codes: <12>

Function:

This control code causes to print actual time/calendar module.

14H

SEND DATE/CALENDAR

Decimal codes: <20>

Hexadecimal codes: <14>

Function:

This control code causes to transmit actual time/calendar on the TxD pin (serial port). This data consist of 11 ASCII characters represented in the following order:

hour - minute - day - month - year

and of a carriage return (ODH).

ESC D **SET DATE IN BUFFER**

Decimal codes: <27><68>

Hexadecimal codes: <1B><44>

Function:

This control code causes to insert the date in the actual position in buffer.

ESC T **SET HOUR IN BUFFER**

Decimal codes: <27><84>

Hexadecimal codes: <1B><54>

Function:

This control code causes to insert the hour in the actual position in buffer.

ESC U **SET HOUR/DATE IN BUFFER**

Decimal codes: <27><85>

Hexadecimal codes: <1B><55>

Function:

This control code causes to insert the date in the actual position in buffer.

The date are in american format: month - date - year

ESC N **L-TYPE MODE**

Decimal codes: <27><78>

Hexadecimal codes: <1B><4E>

Function:

This control code causes to print from left side.

ESC R **R-TYPE MODE**

Decimal codes: <27><82>

Hexadecimal codes: <1B><52>

Function:

This control code causes to inverse print from right side.

ESC s	TRANSMIT CHARACTER
--------------	---------------------------

Decimal codes: <27><115>

Hexadecimal codes: <1B><73>

Function:

This control causes to transmit the next character received.

The sequence "ESC s A" will not print character "A", but it will be transmitted in serial. If we use this function in memorizing blocks of text, we can simulate a password which would be transmitted, for example, when the printer is switched on, or command codes on pressing the PRINT key, or connected printer tests.

4.2.- TEXT PRINTING

00H	NORMAL CHARACTER MODE
------------	------------------------------

Decimal codes: <00>

Hexadecimal codes: <00>

Function:

This code sets normal characters mode.

01H	DOUBLE WIDTH SELECTION
------------	-------------------------------

Decimal codes: <01>

Hexadecimal codes: <01>

Function:

This code sets double width characters mode.

02H	DOUBLE HEIGHT SELECTION
------------	--------------------------------

Decimal codes: <02>

Hexadecimal codes: <02>

Function:

This code sets double height characters mode.

03H **DOUBLE WIDTH DOUBLE HEIGHT SELECTION**

Decimal codes: <03>

Hexadecimal codes: <03>

Function:

This code sets double height and double width characters mode.

04H **NORMAL CHARACTER MODE**

Decimal codes: <04>

Hexadecimal codes: <04>

Function:

This code sets normal characters mode.

ESC w n **DOUBLE HEIGHT SELECTION**

Decimal codes: <27><119><n>

Hexadecimal codes: <1B><77><n>

Function:

This code sets double height characters mode.

If $n = "1"$ sets on the double height characters. If $n = "0"$ sets off the double height characters.

"0" is the ASCII character number 48 decimal, 30 hexadecimal.

"1" is the ASCII character number 49 decimal, 31 hexadecimal.

ESC W n **DOUBLE WIDTH SELECTION**

Decimal codes: <27><87><n>

Hexadecimal codes: <1B><57><n>

Function:

This code sets double width characters mode.

If $n = "1"$ sets on the double width characters. If $n = "0"$ sets off the double width characters.

"0" is the ASCII character number 48 decimal, 30 hexadecimal.

"1" is the ASCII character number 49 decimal, 31 hexadecimal.

4.4.- GRAPHICS LAYOUT

Before connecting any data interface, check the correct operation of printer using self-test feature. To enter self-test mode, user must power the printer on with paper feed button pressed.

PANEL-10 printer allows printing of bitmap graphics and images. Graphic mode is entered with an escape sequence.

Before using printer graphic command, it's important to describe the format and layout of the image to be printed.

A bitmap picture may be considered as a two - dimensional array of bits. Each bit corresponds to a graphic dot (called "pixel") of the image. If bit is at logical state '1' pixel is not printed. If bit is at logical state '0' pixel is printed.

Because of memory configuration, bits are grouped in bytes of 8 bits each one. However, pixels in the image are grouped in bytes, too.

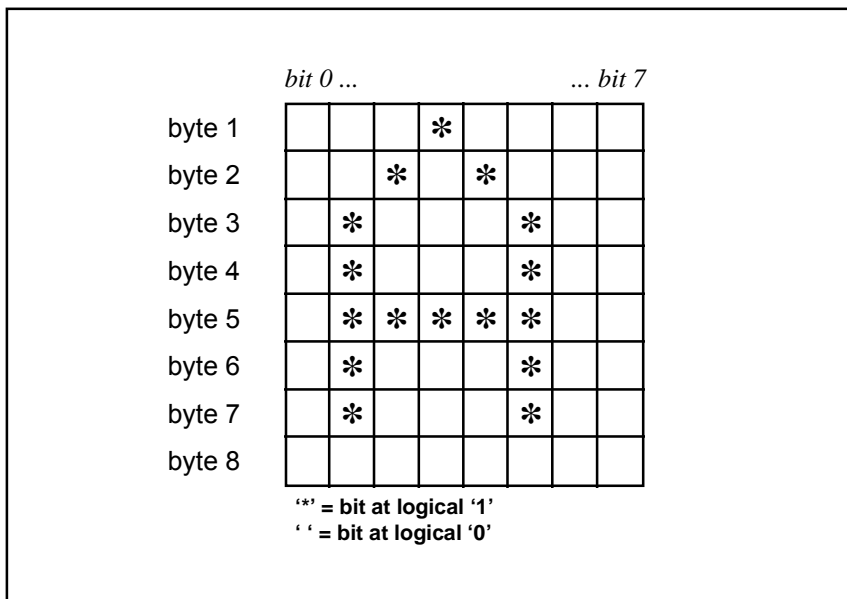

Fig. 4.2- Example of bitmap graphic

Picture is then represented by an array of bytes, each byte having 8 horizontal pixels (bits) of the image. Bytes are grouped in graphics rows. Each row in printer mechanism contains :

18 bytes x 8 bits = 144 pixels in a row (EPSON M190, M180 and M190G mechanisms)

30 bytes x 8 bits = 240 pixels in a row (EPSON M192 and M192G mechanisms)

32 bytes x 8 bits = 248 pixels(31bytes+4 bits) in a row (EPSON M183 mechanisms)

This is a fixed number and user cannot change it. Number of rows is freely configured by user and is limited to a maximum of 65535 in each graphic command.

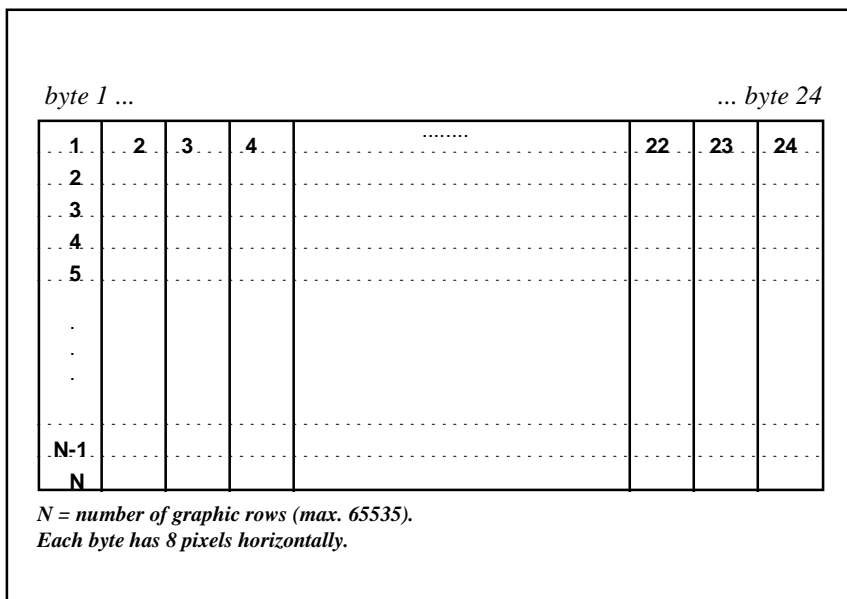

Fig. 4.3- Bitmap image layout

To enter the graphics mode there is available one escape sequence

ESC	V	n1	n2	data
------------	----------	-----------	-----------	-------------

where:

- ESC is escape character (27 dec., 1B hex.)
- V is "V" character (uppercase)
- n1 is number of graphics rows in binary format (low byte)
- n2 is number of graphics rows in binary format (high byte)
- data are bit image data to print

For example, if graphic data of 'A' character is:

row 1 -	00010000 bin = 10 hex
row 2 -	00101000 bin = 28 hex
row 3 -	01000100 bin = 44 hex
row 4 -	01000100 bin = 44 hex
row 5 -	01111100 bin = 7C hex
row 6 -	01000100 bin = 44 hex
row 7 -	01000100 bin = 44 hex

To print this letter in graphic mode, we can send the following sequence of bytes:

1B hex	character ESC = 1B hex = 27 dec.
"V"	character V
7	character number 7 = 7 graphic rows (low byte)
0	character number 0 = 7 graphic rows (high byte)
10 hex	first row of 'A' character
0 (23 times)	character number 0 (23 times to complete the 24 bytes row)
28 hex	second row of 'A' character
0 (23 times)	character number 0 (23 times to complete the 24 bytes row)
44 hex	third row of 'A' character
0 (23 times)	character number 0 (23 times to complete the 24 bytes row)
44 hex	fourth row of 'A' character
0 (23 times)	character number 0 (23 times to complete the 24 bytes row)
7C hex	fifth row of 'A' character
0 (23 times)	character number 0 (23 times to complete the 24 bytes row)
44 hex	sixth row of 'A' character
0 (23 times)	character number 0 (23 times to complete the 24 bytes row)
44 hex	seventh row of 'A' character
0 (23 times)	character number 0 (23 times to complete the 24 bytes row)

4.5.- PRINTER COMMAND SUMMARY

CONTROL	DECIMAL CODE	HEXADECIMAL CODE	FUNCTION
CAN	<24>	<18>	clear input buffer
CR	<13>	<0D>	print and skip line
LF	<10>	<0A>	print and skip line
ESC "J" n	<27><74><n>	<1B><4A><n>	long paper feed
ESC "j" n	<27><106><n>	<1B><6A><n>	short paper feed
ESC "@"	<27><64>	<1B><40>	control board reset
ESC "h" n d	<27><104> <n><d>	<1B><68> <n><d>	set time/calendar
ESC "H"	<27><72>	<1B><48>	print time/calendar
ESC "w" "1"	<27><119><49>	<1B><77><31>	double height on
ESC "w" "0"	<27><119><49>	<1B><77><30>	double height off
ESC "W" "1"	<27><87><49>	<1B><57><31>	double width on
ESC "W" "0"	<27><87><48>	<1B><57><30>	double width off
ESC "-" "1"	<27><45><49>	<1B><2D><31>	underline on
ESC "-" "0"	<27><45><48>	<1B><2D><30>	underline off
ESC "V" n1 n2	<27><86> <n1><n2>	<1B><56> <n1><n2>	bit image graphics lines=n1+ 256 x n2
	<00>	<00>	normal character
	<01>	<01>	double width
	<02>	<02>	double height
	<03>	<03>	double width/height
	<04>	<04>	normal character
	<n><11>	<n><0B>	paper feed
	<15>	<0F>	mode CRLF
	<18>	<12>	print date/time
	<17>	<11>	bit image graphics
	<19>	<13>	set date/time
	<20>	<14>	send date/time
ESC "R"	<27><82>	<1B><52>	reverse mode
ESC "N"	<27><78>	<1B><4E>	normal mode
ESC "s"	<27><115>	<1B><73>	transmit character
ESC "D"	<27><68>	<1B><44>	set date in buffer
ESC "T"	<27><84>	<1B><54>	set hour in buffer
ESC "U"	<27><85>	<1B><55>	set date in buffer(USA)

APPENDIX A – PANEL10 PHYSICAL DIMENSIONS

Fenix Imvico supplies PANEL – 10 impact printer series as a terminated product where the printing mechanism and its suitable interface have been incorporated to a plastic chassis with the purpose of panelling the system.

This chassis provides PANEL - 10 impact printers with a receptacle to allocate the paper roll, a cover which can be pulled out in order to replace the paper roll, a paper feed button and a power on LED indicator.

PANEL – 10 impact printer series is specially designed to be fixed to panel mechanisms. Following pictures show its shapes and dimensions.

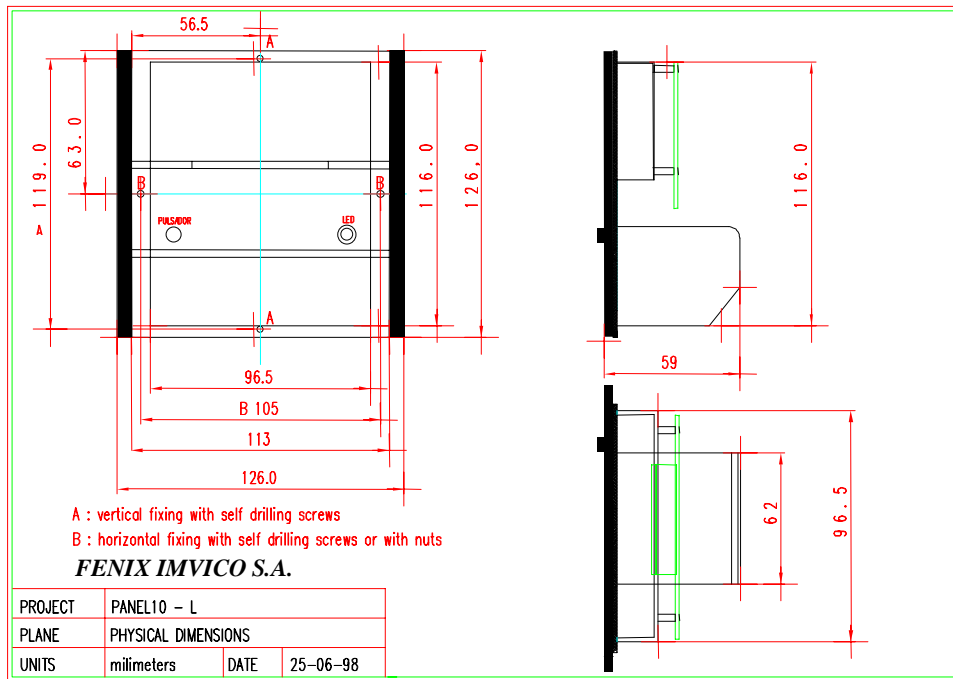

Fig A.1- Physical dimensions for PANEL – 10 impact printers (L - chassis).

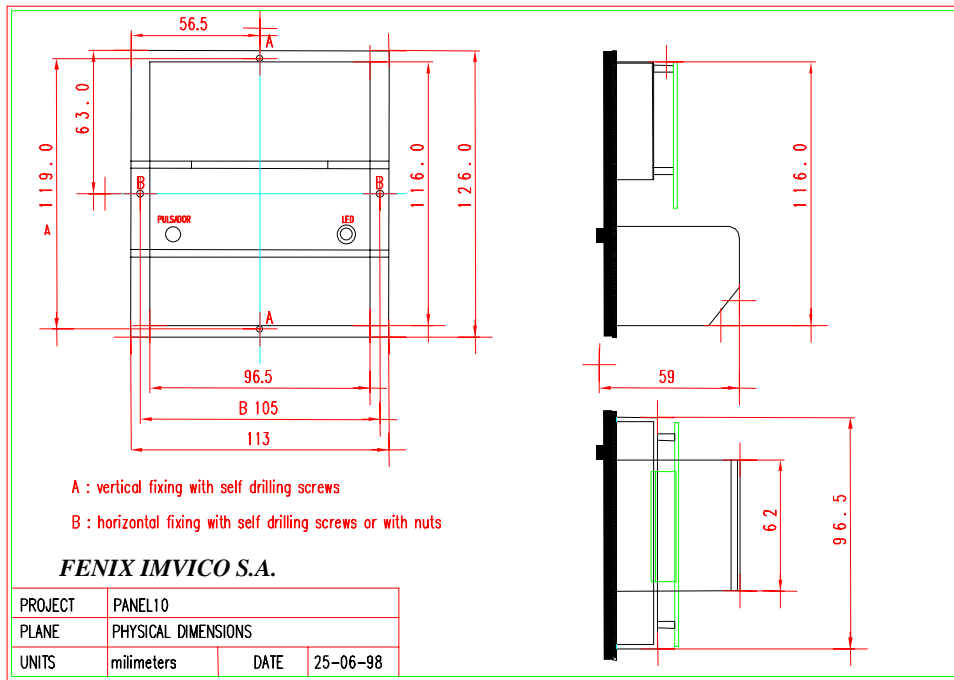

Fig. A.2- Physical dimensions for PANEL – 10 impact printers (normal chassis).

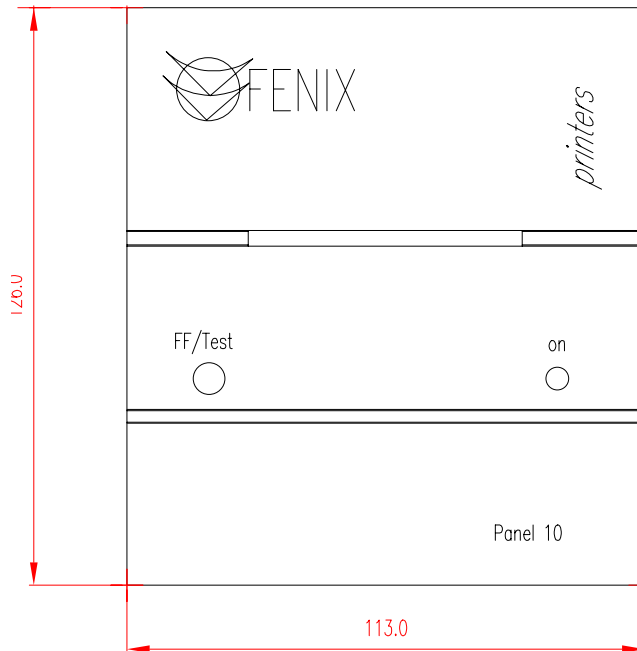

Fig. A.3- External cover for PANEL – 10 impact printers.

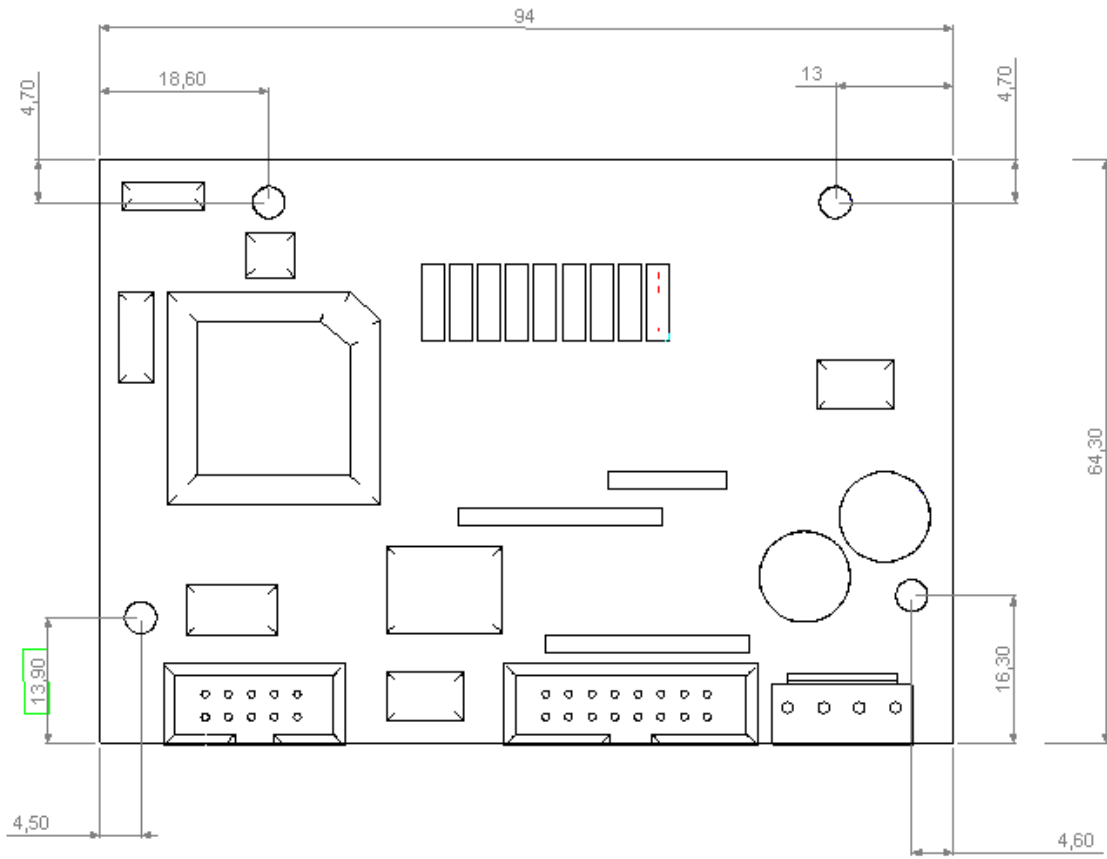

Fig. A.4.- IF180X / IF190X physical dimensions and hole placements.

APPENDIX B - TROUBLESHOOTING

This chapter covers the most common problems with PANEL-10 operation, and what to do:

Printer does nothing

- 1 -Verify power supply voltages.
- 2 -Verify power supply connections.
- 3 -Verify interface connections (RS-232 or parallel CENTRONICS).
- 4 -Use self-test feature to check the printer.

Printer does not function properly

- 1 -Check configuration parameters of printer.
- 2 -Use self - test feature to verify current configuration.

Printing is step by step

- 1 -Verify power supply voltage.

APPENDIX C - SOFTWARE EXAMPLES

This chapter shows some software examples using PANEL-10 printer. Code fonts and executable files are in a floppy disk supplied with the printer.

APPENDIX D - SPECIFICATIONS

	M-180	M-183	M-190	M-192	M-190G	M-192G
Printing method	Impact					
Printing Mechanism	EPSON M-180	EPSON M-183	EPSON M-190	EPSON M-192	EPSON M-190G	EPSON M-192G
Data input Interface	Parallel CENTRONICS Serial RS-232C					
Dots/line composition	144	252	144	240	144	240
Printing speed (lines/sec)	1.7	1	2.5	1.5	2.7	1.8
Paper width	57.5 mm					
Paper weight	47 g / m ²					
Printing width	46 mm					
Character/line	24	42	24	40	24	40
Operating voltage range	5V +/- 5% dc 6A peak max.		5V +/- 5% dc 7,5A peak max.			
Character dot matrix	5x7 (PC-437)					
Dimensions WxDxH	110 x 55 x 126 mm					
Weight	300 grs					

RIBBON CASSETTE SPECIFICATIONS		
Product Number	ERC-09	ERC-22
Size (mm)	90,9(W)x24,9(D)x7,0(H)	90,9(W)x26,4(D)x6,3(H)
Weight	Approx. 3,5 g	Approx. 4,0 g
Life(in Characters) At 4,8vDC 25° (*)	Purple : Approx. 250000 Black : Approx. 200000	Purple: Approx. 1 million Black : Approx. 600000
Colour	Purple or black	
Humidity during Operation	40°C x 80%RH	

(*) Continuous printing.

APPENDIX E – HOW TO ORDER

To order one of the **PANEL – 10** complete printers, refer to **Fig. E.1**:

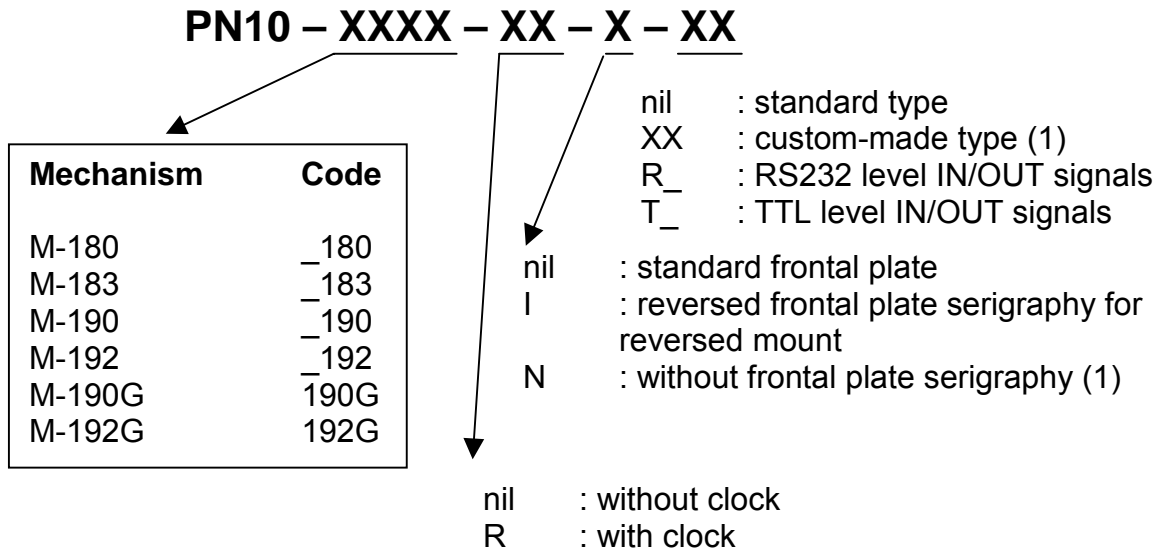

(1) Under agreement only.

Fig. E.1 How to order **PANEL – 10** printers.

To order the **INTERFACE + MECHANISM** kit (without chassis), refer to **Fig. E.2**:

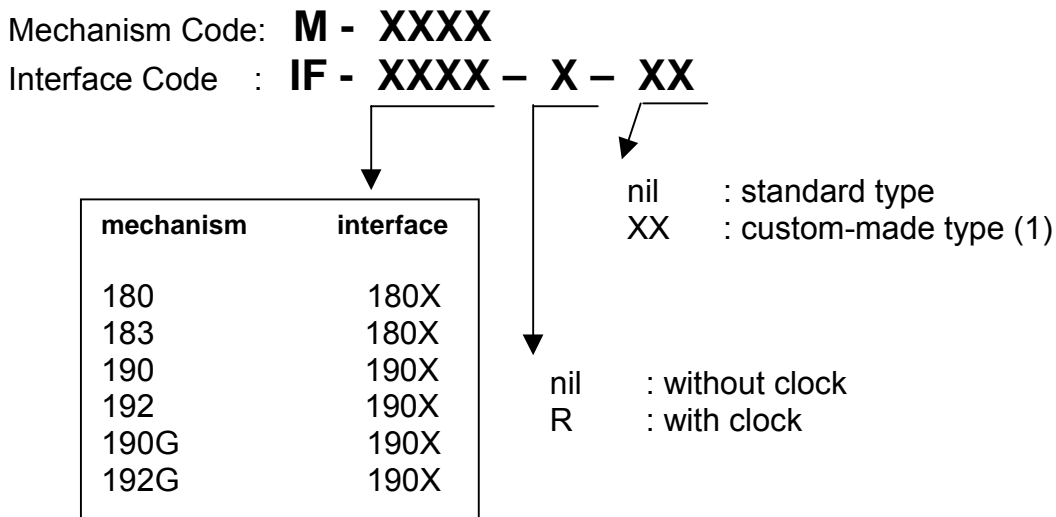

(1) Under agreement only.

Fig. E.2 How to order **INTERFACE + MECHANISM** kit.