

SMART TICKET INTEGRATION GUIDE

INTELLIGENCE IN VALIDATION



MANUAL AMENDMENTS

Rev.	Date	Amendment Details	Issued by
	18-01-13	First Issue	AB

SMART TICKET MANUAL - INTRODUCTION

MANUAL AMENDMENTS	1
COPYRIGHT	4
LIMITED WARRANTY	4
PRODUCT SAFETY INFORMATION	4
INTRODUCTION	5
FEATURES	6
TYPICAL APPLICATIONS	6
1. QUICK START AND CONFIGURATION GUIDE	7
1.1 Assembly	7
1.2 Bezel Removal and Replacement	9
1.3 Earth Bonding	10
1.5 DIP Switch Settings	11
1.5 Connectors and Pinouts	12
1.6 Technical Specifications	15
1.7 SMART Ticket Error Codes	17
1.8 NV200 Bezel Flash Codes	17



MAIN HEADQUARTERS

Innovative Technology Ltd
Derker Street – Oldham – England - OL1 4EQ
Tel: +44 161 626 9999 Fax: +44 161 620 2090
E-mail: support@innovative-technology.co.uk
Web site: www.innovative-technology.co.uk



BRAZIL

suporte@bellis-technology.com.br

CHINA

support@innovative-technology.co.uk

GERMANY

supportDE@innovative-technology.eu

SPAIN

supportES@innovative-technology.eu

UNITED KINGDOM

support@innovative-technology.co.uk

UNITED STATES OF AMERICA

supportusa@bellis-technology.com

REST OF THE WORLD

sales@innovative-technology.co.uk



COPYRIGHT

This manual set is Copyright © Innovative Technology Ltd. 2013. No part of this publication may be reproduced in any form or by any means or used to make any derivative such as translation, transformation, or adaptation without permission from Innovative Technology Ltd. The contents of this manual set may be subject to change without prior notice.

LIMITED WARRANTY

Innovative Technology Ltd warrants each of its hardware products to be free from defects in workmanship and materials under normal use and service for a period commencing on the date of purchase from Innovative Technology Ltd or its Authorized Reseller, and extending for the length of time stipulated by Innovative Technology Ltd.

A list of Innovative Technology Ltd offices can be found in every section of this manual set. If the product proves defective within the applicable warranty period, Innovative Technology Ltd will repair or replace the product. Innovative Technology Ltd shall have the sole discretion whether to repair or replace, and any replacement product supplied may be new or reconditioned.

The foregoing warranties and remedies are exclusive and are in lieu of all other warranties, expressed or implied, either in fact or by operation of law, statutory or otherwise, including warranties of merchantability and fitness for a particular purpose.

Innovative Technology Ltd shall not be liable under this warranty if it's testing and examination disclose that the alleged defect in the product does not exist or was caused by the customer's or any third person's misuse, neglect, improper installation or testing, unauthorized attempts to repair, or any other cause beyond the range of the intended use. In no event will Innovative Technology Ltd be liable for any damages, including loss of profits, cost of cover or other incidental, consequential or indirect damages arising out the installation, maintenance, use, performance, failure or interruption of a Innovative Technology Ltd product, however caused.

PRODUCT SAFETY INFORMATION

Throughout this manual set, we may draw your attention to key safety points that you should be aware of when using or maintaining the product.

These safety points will be highlighted in a box, like this:

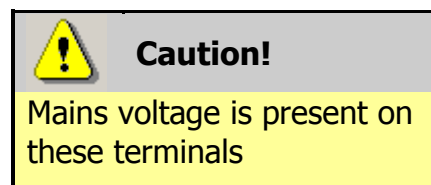

This manual set and the information it contains is only applicable to the model stated on the front cover, and must not be used with any other make or model.



INTRODUCTION

The SMART Ticket unit is made up of three basic components: an NV200 Validator, a cashbox and a ticket module (as shown below). The smart ticket module is an add-on designed to be fitted to the Innovative Technology NV200 bank note validator.

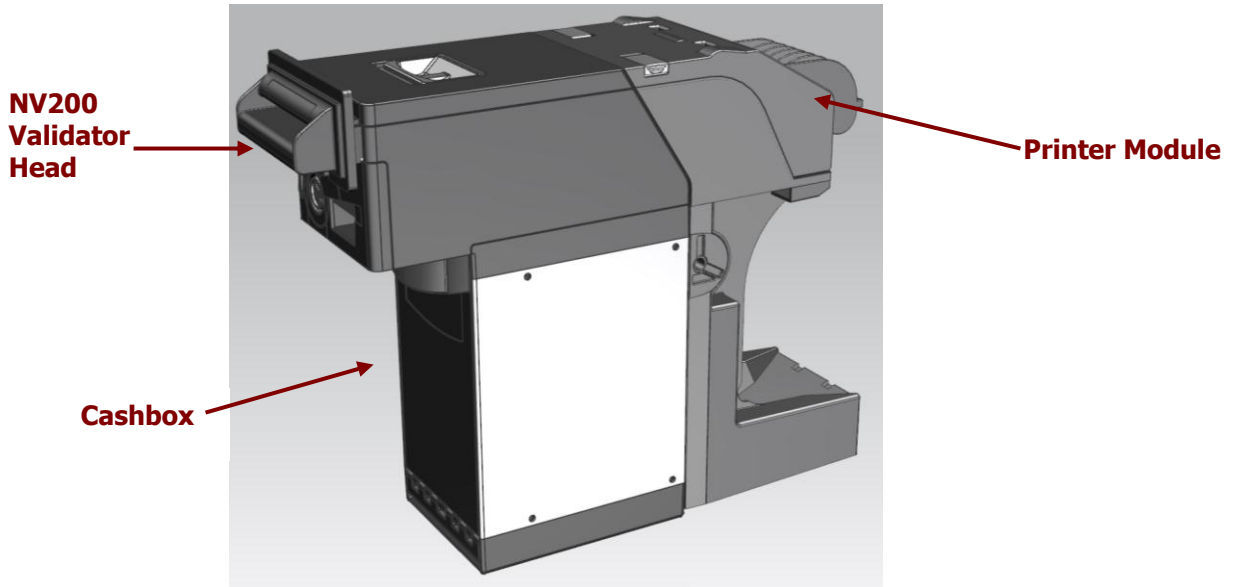

**Smart Ticket
Front View**

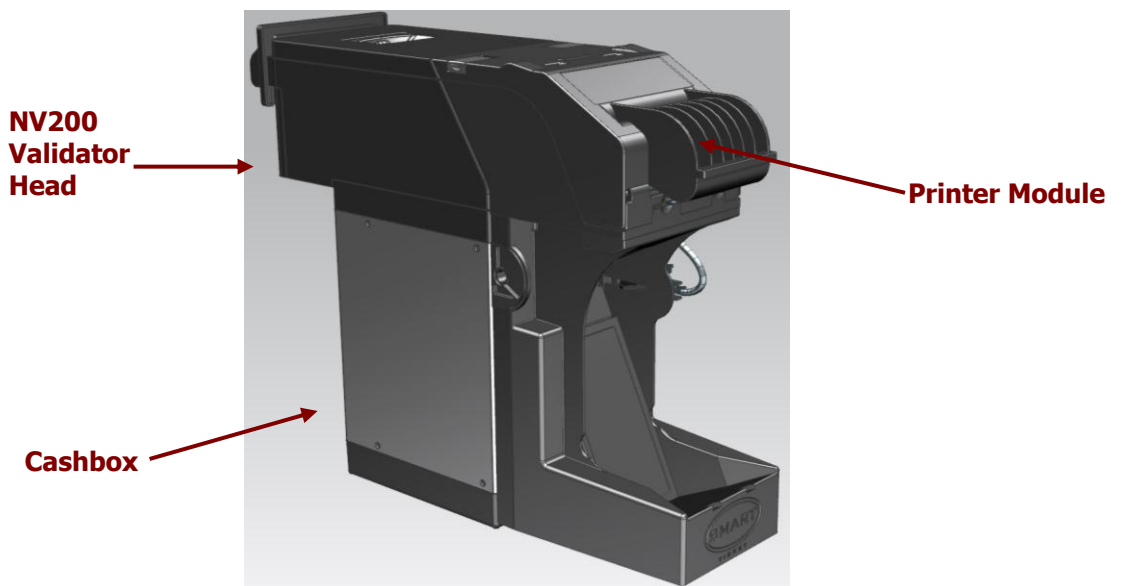

**Smart Ticket
Rear View**

FEATURES

The SMART Ticket unit has many innovative features, including:

- Combined bank note validator & ticket printer
- Market leading design
- Eliminates the need for coin hoppers
- Easy maintenance, free firmware updates
- Fan folded or continuous roll ticket options.

TYPICAL APPLICATIONS

The SMART Ticket unit can be used in a variety of situations where bank note acceptance, validation and ticket printing are needed. Some typical applications are:

- AWP and SWP applications
- Self-Serve and Retail
- Kiosks
- Casinos
- Parking and Ticketing
- Vending



1. QUICK START AND CONFIGURATION GUIDE

This section is one part of a complete manual set: most users should use this section of the manual - typical users are software engineers looking at how to make it work, project engineers evaluating their first unit, or installation engineers installing the unit into a host machine.

This section contains the essential information that a user needs to quickly assemble and configure the SMART Ticket unit ready for installation into the host machine.

1.1 Assembly

The Smart Ticket module is designed to be fitted to the Innovative Technology NV200 bank note validator. Connecting the SMART Ticket module to an NV200 validator is a simple operation, described in the steps outlined here:

1. Remove the NV200 cash box from the metal chassis
2. If installing into a host machine, the NV200 chassis is then mounted by using the tapped holes on either side of the chassis using 4 x M4 fixing screws and a suitable mounting bracket



Information

Check fixing screw length before final installation to avoid damage to the cash box.

The length of the fixing screws fitted to either side of the chassis must be no longer than 6 mm plus the thickness of the mounting bracket.

3. Unlock the NV200 cashbox and head release lock (if fitted)
4. Lift the silver head release catch located on the front of the NV200
5. Slide the head unit forward and lift up

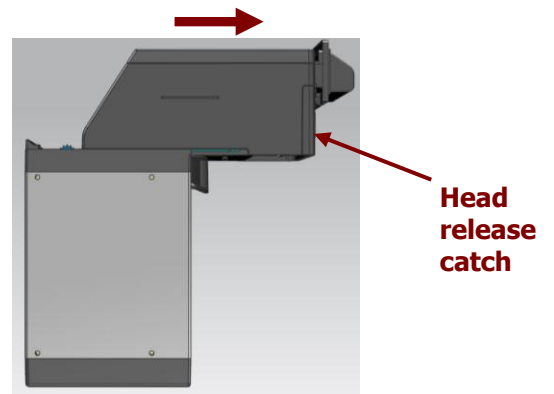

6. Mount the printer module using the mounting brackets on the rear of the NV200 chassis
7. Replace the NV200 head unit taking care that the connectors on the printer module line up with the connectors on the rear of the NV200

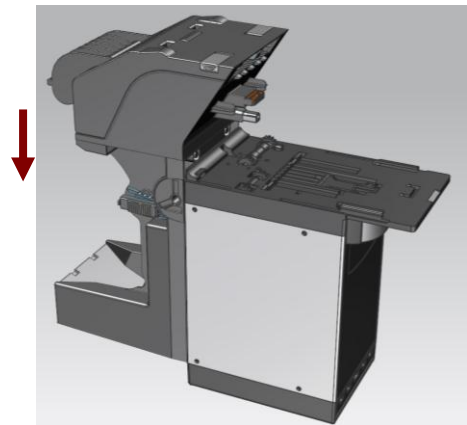

8. Ensure the NV200 head unit is securely in place – check that the release catch is fully down

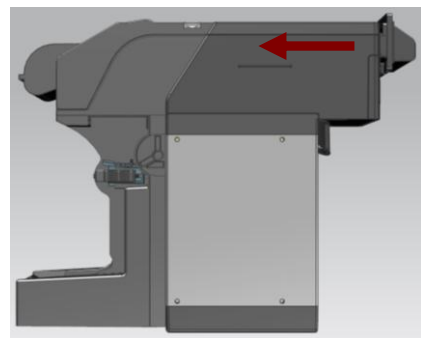
**Information**

Printer module removal.

The printer module cannot be removed until the head unit has been slid forwards.

1.2 Bezel Removal and Replacement

WARNING!
Ensure bezel is secured to validator

The front bezel should be secured to the validator head using screws if the SMART Ticket unit is being installed and transported inside a host machine.

Information
Check bezel fixing screw length before installation.

The length of the bezel fixing screws must be no more than 12 mm in length.

The bezel on the front of the validator head has been designed to be removed and refitted very easily.

To remove or refit the bezel the top cover must be open fully to allow access to the bezel mounting area.

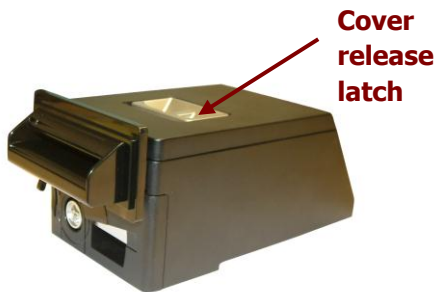

Validator note path cover

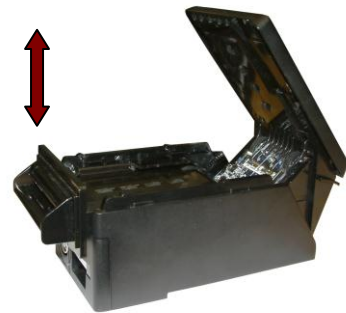

Bezel removal and fitting

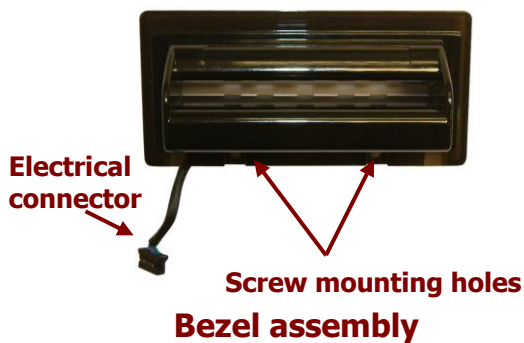

Bezel connector socket



Removing the bezel: Lift the upper cover by pulling the top latch forward. If fitted, remove the two bezel securing screws and then slide the bezel assembly upwards. Finally unplug the cable from the socket on the front of the validator head.

Fitting the bezel: Lift the upper cover by pulling the latch forward. Connect the cable from the bezel assembly to the socket located on the front of the validator head and slide the assembly down into place and then close the note path upper cover. If required, the bezel can be secured in place with two M3 screws - these are fitted in the two holes at the bottom of the bezel.

1.3 Earth Bonding

It is **very** important that the cashbox chassis is bonded to earth, as lack of proper bonding can cause communication issues and failures with the SMART Ticket unit.

The earth bond should be made to any of the 8 holes in the side of the cashbox and be bonded to mains earth, typically through the Power Supply Unit.



Information

Earth resistance.

The resistance between the cashbox and the Earth pin on the mains plug should be less than 0.7 ohms.



1.5 DIP Switch Settings

The SMART Ticket has 4 configuration switches to set the various options for the unit. These options are triggered by pressing and holding the action button at the rear of the SMART Ticket.

Action	Dip 1	Dip 2	Dip 3	Dip 4
Device prints a single test ticket	OFF	OFF	OFF	OFF
Device prints a single test ticket. Enters an error state if the tickets are low.	OFF	OFF	OFF	ON
Device prints a single barcode ticket.	ON	OFF	OFF	OFF
Device prints a single barcode ticket. Device enters an error state if the tickets are low.	ON	OFF	OFF	ON



1.5 Connectors and Pinouts

The SMART Ticket has multiple connectors that are used to allow interfacing and programming.

Information

Power always required regardless of connection type.

Power for the NV200 is always required on pins 1 and 9 of the 16 way connector. Power for the Ticket Module is always required on the 4 way connector.



Pins	Reference	Comment
1	GND_NV200	GND for NV200.
2	N/A	Reserved for future use.
3	RS232_RXD_TITO	RS232 (Host to TITO)
4	OPTO- _RXD_NV200	Opto isolation (Host to NV200)
5	TTL_RXD_TITO	TTL (Host to TITO)
6	OPTO+ _RXD_NV200	Opto isolation (Host to NV200)
7	TTL_TXD_TITO	TTL (TITO to Host)
8	OPTO_EMITTER_TXD_NV200	Opto isolation (NV200 to Host)
9	V_IN_NV200	+12V or +24V supply
10	N/A	Not connected
11	RS232_RXD_NV200	RS232 (Host to NV200)
12	RS232_TXD_TITO	RS232 (TITO to Host)
13	OPTO_COLLECTOR_TXD_NV200	Opto isolation (NV200 to Host)
14	TTL_RXD_NV200	TTL (Host to NV200)
15	RS232_TXD_NV200	RS232 (NV200 to Host)
16	TTL_TXD_NV200	TTL (NV200 to Host)



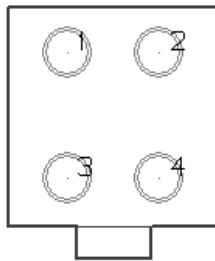
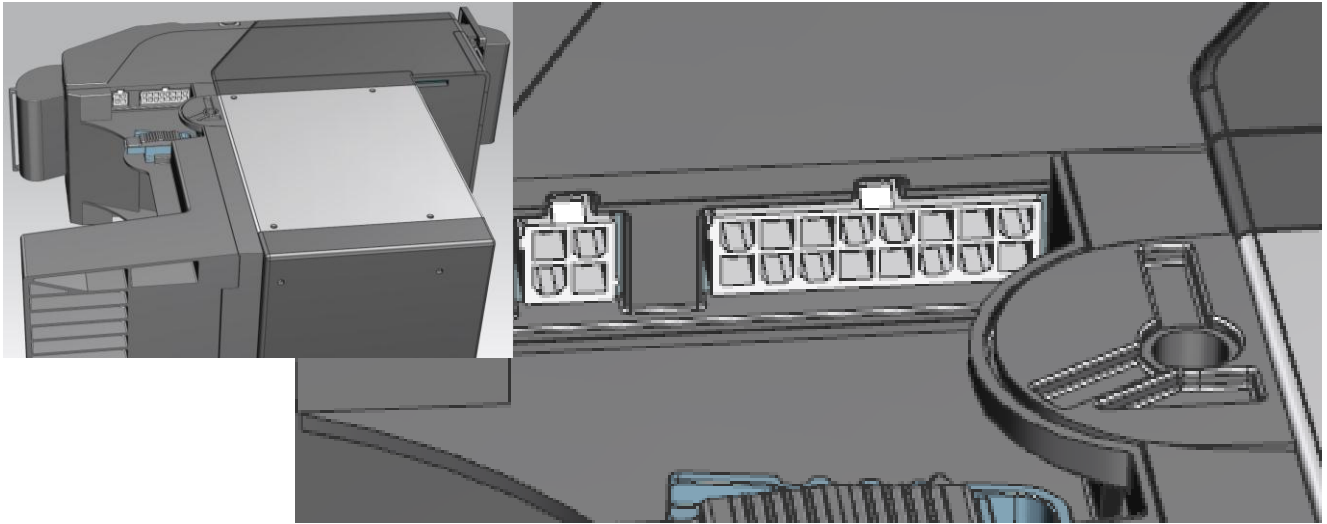

Pins	Reference	Comment
1	V_IN_TITO	+24V supply
2	GND	GND for TITO. Also linked to GND for NV200.
3	V_IN_TITO	+24V supply
4	GND	GND for TITO. Also linked to GND for NV200.

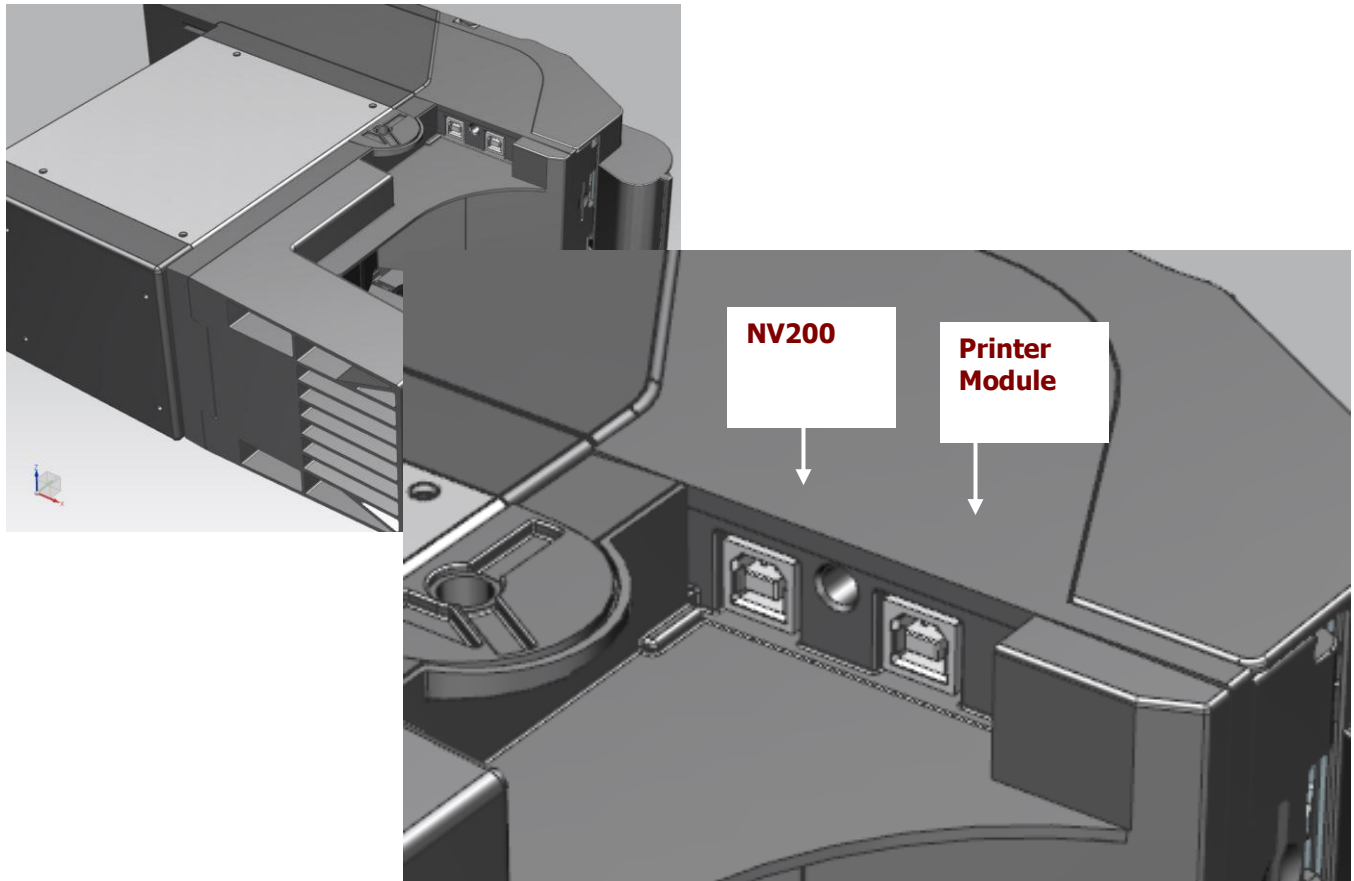

The USB connectors are standard Type 'B' USB socket, and can be used for interfacing to the host machine – in this case, power must be provided through the 16 way connector & 4 way connector. The USB sockets can also be used for programming the Printer Module & the NV200 units – USB 2.0 compliant Type 'A' to 'B' lead can be used to do this. USB cables should be electrically shielded and less than 5 metres long.

1.6 Technical Specifications

NV200

DC Voltage	Minimum	Nominal	Maximum
Absolute limits	10.8 V	12 V	24 V
Supply ripple voltage	0 V	0V	0.25 V @ 100 Hz
Supply Current			
Standby			400 mA
Running			1.5 A
Peak (motor stall)			3 A

Interface Logic Levels	Logic Low	Logic High
Inputs	0 V to 0.5 V	+3.7 V to +12 V
Outputs (2.2 k Ω pull-up)	0.6 V	Pull-up voltage of host interface
Maximum current sink		50 mA per output

Printer Module

DC Voltage	Minimum	Nominal	Maximum
Absolute limits	22 V	24 V	30 V
Supply ripple voltage	0 V	0V	0.5 V @ 100 Hz
Supply Current			
Standby			200 mA
Printing			2.5 A
Peak (motor stall)			8 A

Interface Logic Levels	Logic Low	Logic High
Inputs	0 V to 0.5 V	+3.7 V to +12 V
Outputs (2.2 k Ω pull-up)	0.6 V	Pull-up voltage of host interface
Maximum current sink		50 mA per output



Functionality	Printing Method	Direct Thermal Printing	
	Dot Pitch	0.125 mm	
	Resolution	496 dots per line	
	Print Width	72mm	
	Print Speed	160mm/s	
	Ticket Print and Present	< 5 Seconds	
	Barcode Types	Interleaved 2 of 5, others by request.	
	Barcode Checking	Tickets checked by the NV200	
	Paper Loading	Automatic feed	
	Graphic resources	An SD card slot is available for storage of extra fonts and images. 16M Bit internal storage available	
	Interface: User	Ticket feed button, 4 dip-switches LEDs: Ready, Paper, Open, Fault.	
	Interface: Protocols	eSSP,	
	Interface: Electrical	Open collector, True RS232, USB	
	Support tools	Template Manager & PIPS	
Performance	Parameter	Min (mm)	Max (mm)
	Ticket Type	Thermal Fan-Fold & Roll	
	Fan Fold Ticket Width	62	65
	Ticket Length		160
	Roll paper width		80
	Ticket Thickness	0.1mm	0.13mm
	Perforation strength	0.7Kg	1.3Kg
	Ticket Capacity	900	
	Print Head Reliability	320,000 tickets	
	Environment	Parameter	Min
Operating temperature (Ambient)		+5°C	+60°C
Humidity		5%	95% Non Condensing



1.7 SMART Ticket Error Codes

The SMART Ticket unit has an inbuilt fault detection facility. If there is a configuration or other error, the Status Indicator LEDs will flash in a particular sequence; a summary of the Flash Codes for the SMART Payout unit is shown below:

		Red			
		1	2	3	4
Yellow	1	No NV200 Connection detected	No Paper	Diverter Not Opened	Unknown Error
	2	Initialisation Fail	Tab Not Found	Diverter Not Closed	Tickets Low
	3	No Print Head	Load Fail	Burst Fail	
	4	Ticket Path Open		Cut Fail	
	5			Unknown Jam	

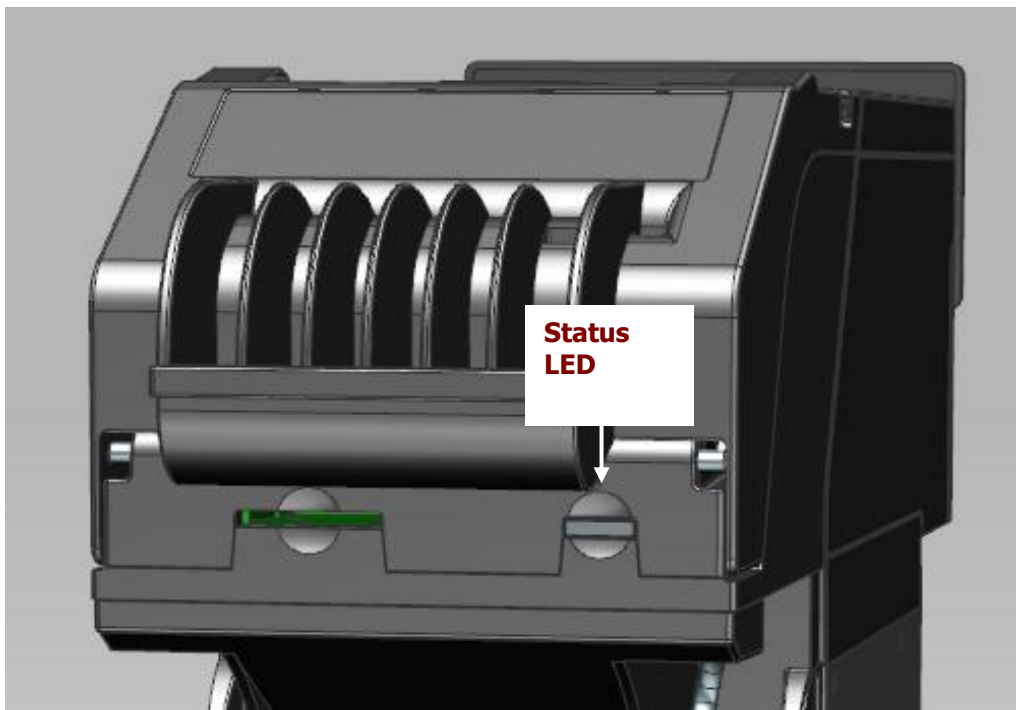

1.8 NV200 Bezel Flash Codes

When the SMART Ticket module is installed on an NV200 bank note validator additional fault finding help is available, as the NV200 has its own set of Flash Codes. These are displayed in the front bezel of the validator.

A summary of the Bezel Flash Codes for the NV200 is shown below:

Flashes		Indicated Error	Comments
Red	Blue		
0	0	None	
1	1	Note path open	Close note path
	2	Note path jam	Remove obstruction and follow the cleaning procedure in Section 2 of this manual set
	3	Unit not initialised	Contact ITL technical support
2	1	Cashbox removed	Refit cashbox
	2	Cashbox jam	Remove trapped notes
3	1	Firmware checksum error	Download new firmware
	2	Interface checksum error	
	3	Dataset checksum error	Download new firmware
	4	EEPROM checksum error	
4	1	Power supply too low	Check power supply
	2	Power supply too high	
	3	Card format	Reprogram programming card
	4	Payout reset	Turn power on and off
5	1	Firmware mismatch	Reprogram unit