



DV Touch SAW Serial Controller Model: DV300LS

Electrical Parameters

Supply Voltage and Current

- +12 VDC, nominal (+9.6 VDC to +13 VDC)
- 85 mA, typical at +12 VDC. Average power dissipation is 1 W, typical.
- Supply must be capable of sourcing 200 mA, minimum.
- Total noise and ripple requirement must be less than 100 mV (p-p) for frequencies below 1 MHz, and less than 50 mV (p-p) for frequencies above 1 MHz.

Interface

- RS232

Touch Resolution

- 4096x4096, size independent, 256 levels of Z (pressure)

Conversion Time

- Less than 15 ms per coordinate set (including transmitting time)

Reliability

- MTBF greater than 250,000 hours per MIL-HDBK-217-F2 using the parts stress calculation method for ground benign environment with an ambient temperature of 25°C.

Environmental Temperature

- Operating: 0°C to 65°C
- Storage: -25°C to 85°C

Humidity

- Operating: 10% to 90% RH, non-condensing
- Storage: 10% to 90% RH, non-condensing

ESD

- Per EN 6100-4-2: Contact discharge 4kV, air discharge 8kV.

Flammability

- The printed circuit board substrate is rated 94V0. All plastic components such as headers and connectors are also rated 94V0.

Physical Characteristics

Construction

- Multi-layer surface-mount design with internal ground plane for EMI suppression

Dimensions

- Total Width: 2.441 inches (62 mm), including connectors
- Total Length: 3.346 inches (85 mm)
- Total height: 0.433 inches (11 mm)

Digital Vision Ltd.

Unit 2201, Lemmi Centre, 50 Hoi Yuen Road, Kwun Tong, Kowloon, Hong Kong
Tel: (852) 35719355 Fax: (852) 27934439



• All mounting holes are plated through for chassis ground connection.
Refer to the drawings at the end of this document.

Operational Systems Support:

- Windows ME/2000/XP (Driver Ver.1.0, 2.01)
- Windows CE on X86 (ask info@digitalvision.com.hk)
- Windows Embedded on X86 (ask info@digitalvision.com.hk)
- Windows Embedded on ARCA (ask info@digitalvision.com.hk)
- Linux (ask info@digitalvision.com.hk)

Digital Vision Ltd.

*Unit 2201, Lemmi Centre, 50 Hoi Yuen Road, Kwun Tong, Kowloon, Hong Kong
Tel: (852) 35719355 Fax: (852) 27934439*

Jumpers & Connectors:

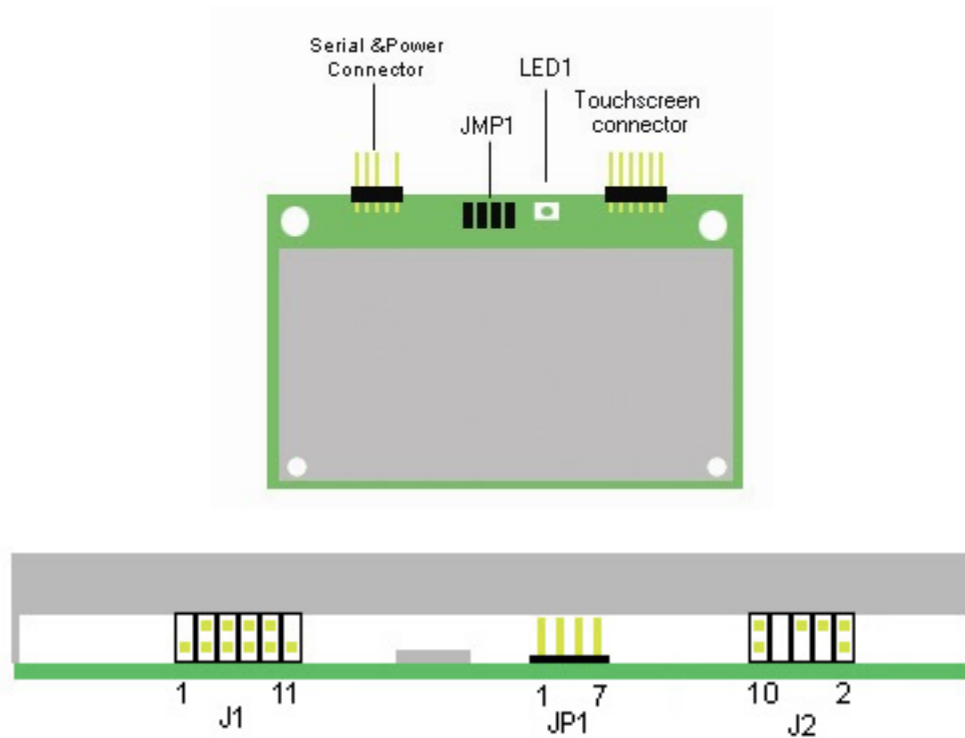

J1			
1	GND	7	GND
2	NC	8	GND
3	Y-in2	9	X-in2
4	Y-out	10	X-out
5	Y-in1	11	X-in1
6	GND	12	NC

J2	
1	TX
2	GND Plate
3	RX
5	GND
9	+12V
10	GND

JMP1(Screen size)		
3-4	ON	8" - 17"
3-4	OFF	18" - 29"

JMP1(Drivers support)		
7-8	ON	DV-Touch or GT
7-8	OFF	MicroTouch

Digital Vision Ltd.

Unit 2201, Lemmi Centre, 50 Hoi Yuen Road, Kwun Tong, Kowloon, Hong Kong

Tel: (852) 35719355 Fax: (852) 27934439